

Contents

1. Safety Precautions
2. Model and Suffix Codes
3. How to Install
4. How to Connect Wires
5. Hardware Specifications
6. Terminal Wiring Diagrams

Introduction
 Thank you for purchasing the UT750 digital indicating controller. The controller is shipped from the factory with 5 hardcopy user's manuals (A2 size) and 1 user's manual on CD-ROM. The 5 user's manuals in hardcopy format describe the operating procedures required for basic use (factory-set to single-loop control mode). It is recommended that you refer to these user's manuals to understand [1] installation, [2] initial settings, and [3] operating procedures of the controller. The CD-ROM contains an User's Manual (Reference) with descriptions of various functions and setting ranges that can be set as necessary. The manual also contains information on operations used to carry out control other than single-loop control. Moreover, the use of an optional parameter setting tool (model: LL100-E10) allows you to easily perform settings and adjustments with a PC.

How to Use the Manuals

Purpose	Manual Title	Description	Media
Setup	Installation	Describes the tasks (installation, wiring, and others) required to make the controller ready for operations.	A2-size paper, back and front
Basic operation	Initial Settings	Describes examples of setting PV input types, control output types, and alarm types. Making settings described herein allows you to carry out basic control.	A2-size paper, back and front
Operating procedures and troubleshooting	Operations	Describes key operation sequences. For operation control through external contact inputs, see the back of User's Manual.	A2-size paper, back and front
Brief operation	Parameter Map	Contains the parameter map used as a guideline for setting parameters.	A2-size paper, back and front
Function description and setpoint recording	Parameters	Briefly describes the functions of parameters. In addition, each parameter table has a User Setting column, where you can record your setpoints when setting them in the controller.	A2-size paper, back and front
Detailed description of functions	User's Manual (Reference)	Explains more advanced applications than those found in the 5 hardcopy user's manuals (A2 size).	CD-ROM

1. Safety Precautions
 The following symbol is indicated on the controller to ensure safe use.

CAUTION

This symbol on the controller indicates that the operator must refer to an explanation in the user's manual in order to avoid the risk of injury or death of personnel or damage to the instrument. The manual describes how the operator should exercise special care to avoid electric shock or other dangers that may result in injury or loss of life.

The following symbols are used in the hardcopy user's manuals and in the user's manual supplied on the CD-ROM.

NOTE
 Indicates that operating the hardware or software in a particular manner may damage it or result in a system failure.

IMPORTANT
 Draws attention to information that is essential for understanding the operation and/or features of the controller.

Exemption from Responsibility
 Make sure that all of the precautions are strictly adhered to. Yokogawa Electric Corporation assumes no liability for any damage resulting from use of the instrument in contradiction to the precautions. Also, Yokogawa Electric Corporation assumes no liability to any party for any loss or damage, direct or indirect, caused by the use of or any unpredictable defect of the instrument.

Regarding Protection, Safety, and Prohibition Against Unauthorized Modification

- (1) In order to protect the product and the system controlled by it against damage and ensure its safe use, make certain that all of the instructions and precautions relating to safety contained in this document are strictly adhered to. Yokogawa does not guarantee safety if products are not handled according to these instructions.
- (2) Modification of the product is strictly prohibited.

2. Model and Suffix Codes
 Before using the controller, check that the model and suffix codes match your order.

Model	Suffix Code	Description
UT750		Digital indicating controller (provided with Custom Computing Function*)
Type	-0	Single-loop type
	-1	Position proportional type
	-5	Dual-loop type
Optional functions	0	None
	1	With communication, auxiliary analog (remote) input

Check that the following items are provided:

- Digital indicating controller (of ordered model): 1
- Brackets (mounting hardware): 1 pair
- Unit label: 1
- User's Manuals for Single-loop Control: 5 (A2 size)
- User's Manual (Reference) (CD-ROM Version): 1

* Using an optional custom computation building tool (Model LL200-E10) that runs on a personal computer, you can build a variety of computations (e.g., four arithmetic operations, logical operations, ten-segment linearizer computations, temperature correction factor computations, and pressure correction factor computations) to be applied to the controller's I/O signals.

3. How to Install

NOTE

To install the controller, select a location where:

- (1) no one may accidentally touch the terminals,
- (2) mechanical vibrations are minimal,
- (3) corrosive gas is minimal,
- (4) temperature can be maintained at about 23°C and the fluctuation is minimal,
- (5) no direct radiant heat is present,
- (6) no magnetic disturbances are caused,
- (7) no wind blows against the terminal board (reference junction compensation element),
- (8) no water is splashed,
- (9) no flammable materials are around.

Never place the controller directly on flammable items or equipment. If the controller has to be installed close to flammable items or equipment, be sure to provide shielding panels all around the controller, at least 150mm away from every side; the panels should be made of either 1.43mm-thick metal-plated steel plates or 1.6mm-thick uncoated steel plates.

Installation Position
 Install the controller at an angle within 30° from horizontal with the front panel facing upward. Do not install it facing downward. The position of right and left sides should be horizontal.

External Dimensions and Panel Cutout Dimensions

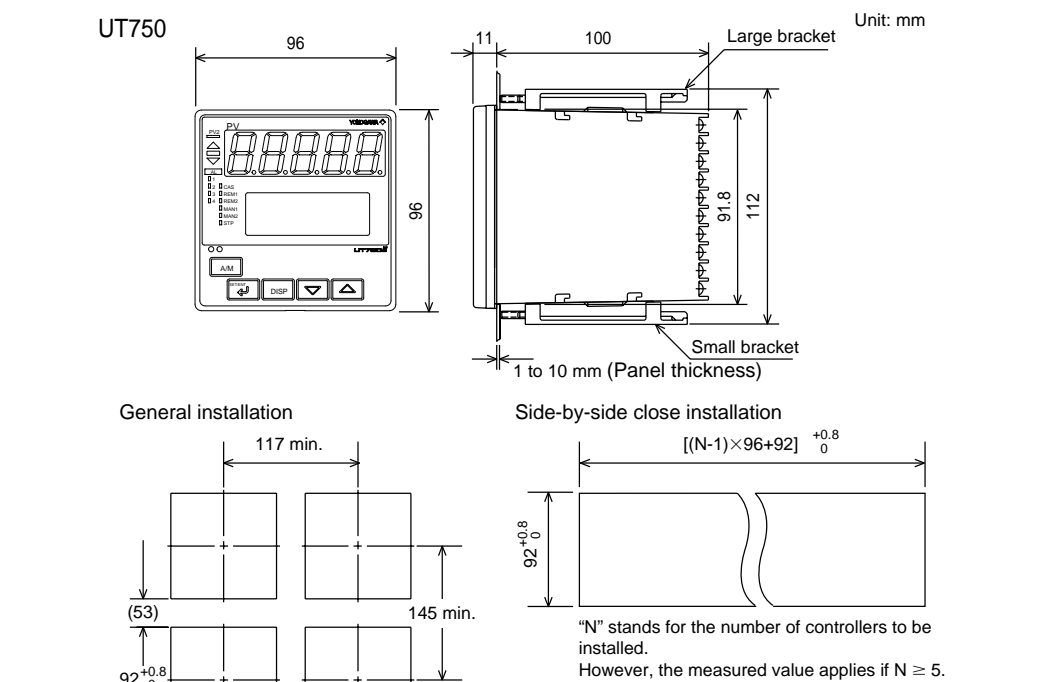

How to Install

CAUTION
 Turn off the power to the controller before installing it on the panel because there is a possibility of electric shock.

After opening the mounting hole on the panel, follow the procedures below to install the controller:

1. Insert the controller into the opening from the front of the panel so that the terminal board on the rear is at the far side.
2. Set the brackets in place on the top and bottom of the controller as shown in the figure on the left, then tighten the screws of the brackets. Take care not to over-tighten them.

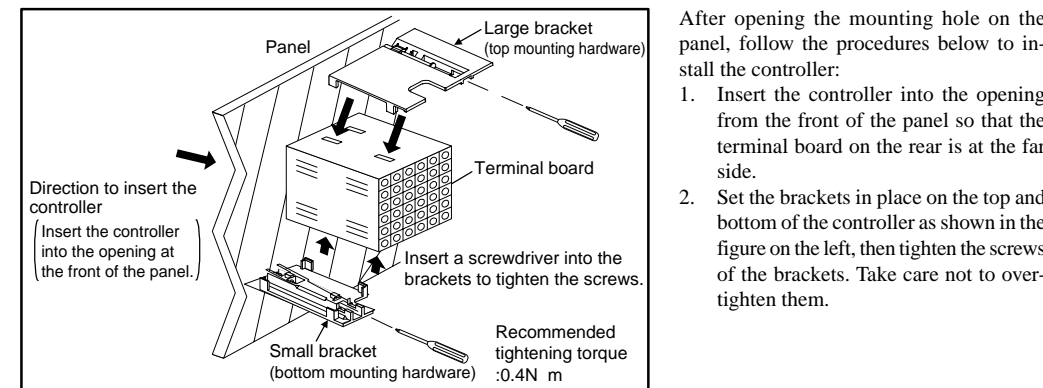

4. How to Connect Wires

CAUTION

- 1) Before carrying out wiring, turn off the power to the controller and check that the cables to be connected are not alive with a tester or the like because there is a possibility of electric shock.
- 2) For the protection and safe use of the controller, be sure to place a circuit breaker (conforms with IEC60947, 5A, 100V or 220V AC) near the controller where the breaker can easily be operated. In addition, be sure to indicate that it is the instrument to cut the power supply of the controller.
- 3) Wiring must be carried out by personnel who have basic electrical knowledge and practical experience.

NOTE

- 1) Provide power from a single-phase instrument power supply. If there is a lot of noise in the power line, insert an insulating transformer into the primary side of the line and use a line filter (recommended part: ZAC2205-00U from TDK) on the secondary side. As a countermeasure against noise, do not place the primary and secondary power cables close to each other.
- 2) For thermocouple input, use shielded compensating lead wires for wiring. For RTD input, use shielded wires that have low conductor resistance and cause no significant differences in resistance between the three wires. The cables to be used for wiring, terminal specifications, and recommended parts are as shown below.
- 3) Control output relays may be replaced. However, because they have a life of 100,000 times that of the resistance load, use auxiliary relays to turn on/off a load.
- 4) The use of inductance (L) loads such as auxiliary relays, motors and solenoid valves causes malfunction or relay failure; always insert a CR filter for use with alternating current or a diode for use with direct current, as a spark-removal surge suppression circuit, into the line in parallel with the load.
- 5) When there's possibility of being struck by external lightning surge, use the arrester to protect the instrument.

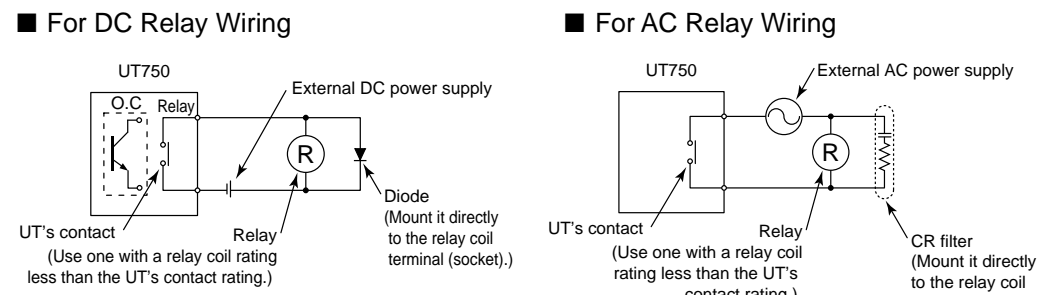

Cable Specifications and Recommended Cables

Purpose	Name and Manufacturer
Power supply, grounding, relay contact outputs	600 V PVC insulated wires, JIS C 3307, 0.9 to 2.0 mm ²
Thermocouple	Shielded compensating lead wires, JIS C 1610, □X□□□□ (See Yokogawa Electric's GS 6B1U1-E.)
RTD	Shielded wires (three conductors), UL2482 (Hitachi Cable)
Other signals	Shielded wires

Recommended Terminal Lugs

Applicable wire size	Tightening torque
0.3 to 1.65 mm ²	0.8 N·m or less

Terminal Covers (Optional parts)

Target Model	Part Number	Sales Unit
For UT750	T9115YD	1

1. Before attaching the terminal cover, bend the side with the groove inward as shown in Fig. A. Be careful not to bend it backwards. This not only marks it harder to attach the cover but will also weaken its hold.
2. Fit the holes on the top and bottom of the terminal cover the projections on the brackets (Fig. B) and lock in place. The figure right shows the attachment of a terminal cover to UT controller.

5. Hardware Specifications

PV Input Signals

- Number of inputs: 1 (terminals ①, ②, ③)
- Input type: Universal input system. The input type can be selected with the software.
- Sampling period: Can be selected from 50, 100, 200 and 500 ms.
- Burnout detection: Functions at TC, RTD, standard signal (0.4 to 2 V or 1 to 5 V) Upscale, downscale, and off can be specified. For standard signal, burnout is determined to have occurred if it is 0.1 V or less.
- Input bias current: 0.05 μA (for TC or RTD b-terminal)
- Measurement current (RTD): About 0.13 mA
- Input resistance: 1 MΩ or more for thermocouple or mV input About 1 MΩ for DC voltage input
- Allowable signal source resistance: 250 Ω or less for thermocouple or mV input Effects of signal source resistance: 0.1 μV/Ω or less 2 kΩ or less for DC voltage input Effects of signal source resistance: About 0.1%/100 Ω
- Allowable wiring resistance: for RTD input Maximum 150 Ω/wire: Conductor resistance between three wires should be equal However, 10 Ω/wire for a maximum range of -150.0 to 150.0°C. Wire resistance effect: ±0.1°C/10 Ω
- Allowable input voltage: ±10 V DC for thermocouple, mV, or RTD input ±20 V DC for DC voltage input
- Noise rejection ratio: 40 dB (50/60 Hz) or more in normal mode 120 dB (50/60 Hz) or more in common mode
- Reference junction compensation error: ±1.0°C (15 to 35°C) ±1.5°C (0 to 15°C, 35 to 50°C)
- Applicable standards: JIS, IEC, DIN (ITS-90) for thermocouples and RTD

Loop Power Supply
 Power is supplied to a two-wire transmitter. (15 V DC; terminals ④-⑤) A resistor (10 to 250 Ω) connected between the controller and transmitter converts a current signal into a voltage signal, which is then read via the PV input terminal. Supply voltage: 14.5 to 18.0 V DC, max. 21 mA (provided with a protection circuit against a field short-circuit)

Retransmission Output
 Either PV, target setpoint, or control output is output. Either the retransmission output or the loop power supply can be used with terminals ⑥-⑦.

- Number of outputs: 1 or 2 (terminals ⑥-⑦, terminals ⑧-⑨)
- Output signal: 4-20, 0-20, 20-4, or 20-0 mA DC (where, outputting signal levels of less than 0 mA is not feasible)
- Load resistance: 600 Ω or less
- Output accuracy: ±0.1% of span (±5% of span for 1 mA or less.) under standard operating conditions (23 ± 2°C, 55 ± 10% RH, power frequency of 50/60 Hz)

Control Output
 Universal output system. The output type can be selected with the software. Relay contact output(s) for the position proportional type

- Current output (Single-loop: terminals ⑩-⑪; heating-side output: terminals ⑩-⑫, cooling-side output: terminals ⑬-⑭)

Number of outputs	Output signal	Load resistance	Output accuracy
1 or 2 (two for heating/cooling control), switched between a voltage pulse output and current output.	4-20, 0-20, 20-4, or 20-0 mA DC	600 Ω or less	±0.1% of span (±5% of span for 1 mA or less) Under standard operating conditions (23 ± 2°C, 55 ± 10% RH, power frequency of 50/60 Hz)

- Voltage pulse output (Single-loop: terminals ⑯-⑰; heating-side output: terminals ⑯-⑱, cooling-side output: Not selected)

Number of outputs	Output signal	Resolution
1	switched between a voltage pulse output and current output.	10 ms or 0.1% of output, whichever is larger

Remote Input Signals
 Available only for controllers with remote input terminals.

- Number of inputs: 1 (terminals ⑲-⑳)
- Input type: Settable in a range of 0-2, 0-10, 0.4-2.0, or 1-5 V DC
- Sampling period: 100, 200 and 500 ms

The sampling period of a remote input signal is associated with the PV input's sampling period. If the PV input's sampling period is 50 ms, however, the sampling period of a remote input signal lengths to 100 ms.

- Input resistance: About 1 MΩ
- Input accuracy: ±0.3% ± 1 digit of input span for 0 to 2 V DC ±0.2% ± 1 digit of input span for 0 to 10 V DC ±0.375% ± 1 digit of input span for 0.4 to 2.0 V DC ±0.3% ± 1 digit of input span for 1 to 5 V DC Under standard operating conditions (23 ± 2°C, 55 ± 10% RH, power frequency of 50/60 Hz)

Feedback Resistance Input
 Provided for position proportional type only (terminals ㉑-㉒)

- Slide resistance value: 100 Ω to 2.5 kΩ of overall resistance (burnout detection for sliding wire provided)
- Measuring resolution: ±0.1% of overall resistance

Relay contact output (Single-loop: terminals ①-③, heating-side output: terminals ①-②, ③, cooling-side output: terminals ④-⑦, position proportional type: terminals ⑧-⑩)

Number of outputs	Output signal	Contact rating	Resolution
1 or 2 (two for heating/cooling control)	Three terminals (NC, NO, and common)	Terminals ①-②-③: 250 V AC or 30 V DC, 3 A (resistance load) Terminals ④-⑦: 240 V AC or 30 V DC, 1A (resistance load)	10 ms or 0.1% of output, whichever is larger

Contact Inputs

- Purpose: Target setpoint selection, remote/local mode switching, and run/stop command
- Number of inputs: 7 points (relay: 3, transistor: 4)
- Input type: Non-voltage contact or transistor open collector input
- Input contact rating: 12 V DC, 10 mA or more
- On/off determination: For non-voltage contact input, contact resistance of 1 kΩ or less is determined as "on" and contact resistance of 20 kΩ or more as "off." For transistor open collector input, input voltage of 2 V or less is determined as "on" and leakage current must not exceed 100 μA when "off."
- Minimum status detection hold time: PV input's sampling period × 3

Contact Outputs

- Purpose: Alarm output, FAIL output, and others
- Number of outputs: 7 points (relay: 3 points, transistor: 4 points)
- Relay contact rating: 240 V AC, 1 A, or 30 V DC, 1 A COM terminal is common.
- Transistor contact rating: 24 V DC, 50 mA COM terminal is common.

Display Specifications

- PV display: 5-digit, 7-segment, red LEDs, character height of 20 mm for UT750
- Setpoint display: 32 × 128 dot LCD display with back-light
- Status indicating lamps: LEDs

Signal Isolations

- PV input terminals: Isolated from other input/output terminals. Not isolated from the internal circuit.
- Remote input terminals: Isolated from other input/output terminals and the internal circuit
- 15 V DC loop power supply terminals: Not isolated from analog current output and voltage pulse control output. Isolated from other input/output terminals and internal circuit.
- Analog output terminals (for control output and retransmission): Not isolated between analog outputs nor from 15 V DC sensor power supply and voltage pulse control output. Isolated from other input/output terminals and internal circuit.
- Voltage pulse control output terminals: Not isolated from analog outputs and 15 V DC loop power supply. Isolated from other input/output terminals and internal circuit.
- Relay contact output terminals: Isolated between contact output terminals and from other input/output terminals and internal circuit.
- Contact input terminals: Not isolated between contact input terminals and from communication terminals. Isolated from other input/output terminals and internal circuit.
- Relay contact output terminals: Not isolated between relay contact outputs. Isolated from other input/output terminals and internal circuit.
- Transistor contact output terminals: Not isolated between transistor contact outputs. Isolated from other input/output terminals and internal circuit.
- RS-485 communication terminals: Not isolated from contact input terminals. Isolated from other input/output terminals and internal circuit.
- Feedback slide resistance input terminals: Not isolated from analog output terminals (control, retransmission), 15 V loop power supply, and voltage pulse control outputs. Isolated from other input/output terminals and internal circuit.
- Power terminals: Isolated from other input/output terminals and internal circuit.
- Grounding terminals: Isolated from other input/output terminals and internal circuit.

Environmental Conditions

- Normal operating conditions: Ambient temperature: 0 to 50°C (40°C or less for side-by-side close installation) Temperature change rate: 10°C/h or less Ambient humidity: 20 to 90% RH (no condensation allowed) Magnetic field: 400 A/m or less Continuous vibration at 5 to 14 Hz: Full amplitude of 1.2 mm or less Continuous vibration at 14 to 150 Hz: 4.9 m/s² or less Short-period vibration: 14.7 m/s², 15 seconds or less Shock: 147 m/s² or less, 11 ms Installation height: Height above sea level of 2000 m or less Warm-up time: 30 minutes or more after power on
- Transportation and storage conditions: Temperature: -25 to 70°C Temperature change rate: 20°C/h or less Humidity: 5 to 95% RH (no condensation allowed)
- Effects of changes in operating conditions
 - Effects from changes in ambient temperature:
 - On voltage or thermocouple input, ±1 μV/°C or ±0.01% of F.S./°C, whichever is larger
 - On remote input, ±0.02% of F.S./°C
 - On RTD input, ±0.05°C/°C (ambient temperature) or less
 - On analog output, ±0.05% of F.S./°C or less
 - Effects from power supply fluctuation (within rated voltage range)
 - On remote input, ±1 μV/10 V or ±0.01% of F.S./10 V, whichever is larger
 - On analog output, ±0.05% of F.S./10 V or less

Safety and EMC Standards

- Safety: Compliant with IEC/EN61010-1: 2001, approved by CSA1010, approved by UL508 Installation category: 2 (IEC/EN61010, CSA1010) Pollution degree: 2 (IEC/EN61010, CSA1010) Measurement category: 1 (CAT. I: IEC/EN61010) Rated measurement input voltage: 10V DC max.(across terminals), 300V AC max.(across ground) Rated transient overvoltage: 1500V (Note) Note: It is a value on the safety standard which is assumed by IEC/EN61010-1 in measurement category I, and is not the value which guarantees an apparatus performance.

CAUTION

This equipment has Measurement category I, therefore do not use the equipment for measurements within measurement categories II, III and IV.

Measurement category	Description	Remarks
I	CAT. I For measurements performed on circuits not directly connected to MAINS.	
II	CAT. II For measurements performed on circuits directly connected to the low voltage installation.	Appliances, portable equipments, etc.
III	CAT. III For measurements performed in the building installation.	Distribution board, circuit breaker, etc.
IV	CAT. IV For measurements performed at the source of the low-voltage installation.	Overhead wire, cable systems, etc.

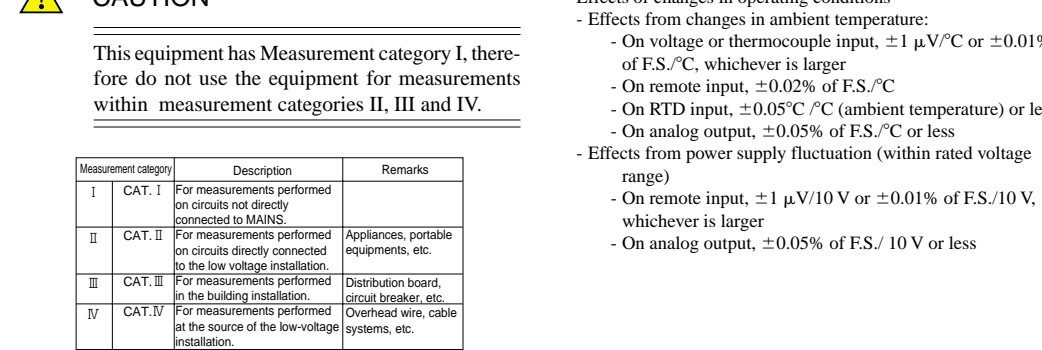

EMC standards: Complies with EN61326. The instrument continues to operate at a measuring accuracy of within ±20% of the range during tests.

Construction, Installation, and Wiring

- Construction: Dust-proof and drip-proof front panel conforming to IP55.
- Front-side-by-side close installation: The controller loses its dust-proof and drip-proof protection.
- Material: ABS resin and polycarbonate
- Case color: Black
- Weight: About 1 kg or less
- Dimensions: 96 (W) × 96 (H) × 100 (depth from panel face) mm
- Installation: Panel-mounting type. With top and bottom mounting hardware (1 each)
- Panel cutout dimensions: 92^{+0.8} (W) × 92^{+0.8} (H) mm
- Installation position: Up to 30° upward facing (not designed for facing downward)
- Wiring: M3.5 screw terminals (for signal wiring and power/ground wiring as well)

Power Supply Specifications

- Power supply: Rated voltage of 100 to 240 V AC (±10%), 50/60 Hz
- Power consumption: Max. 20 VA (8.0 W max.)
- Internal fuse rating: 250 VAC, 1.6A time-lag fuse
- Data backup: Lithium cell with life expectancy of 10 years
- Withstanding voltage
 - Between primary terminals* and secondary terminals**:
 - At least 1500 V AC for 1 minute
 - Between primary terminals* and grounding terminal:
 - At least 1500 V AC for 1 minute
 - Between grounding terminal and secondary terminals**:
 - At least 1500 V AC for 1 minute
 - Between secondary terminals**:
 - At least 500 V AC for 1 minute
- * Primary terminals indicate power terminals and relay output terminals
- ** Secondary terminals indicate analog I/O signal, voltage pulse output, and contact input terminals
- Insulation resistance: 20 MΩ or more at 500 V DC between power terminals and grounding terminal
- Grounding: Class D grounding (grounding resistance of 100 Ω or less)

6. Terminal Wiring Diagrams

NOTE
Do not use unassigned terminals as relay terminals.

UT750 Single-loop Control (Model UT750-0□ or UT750-5□)

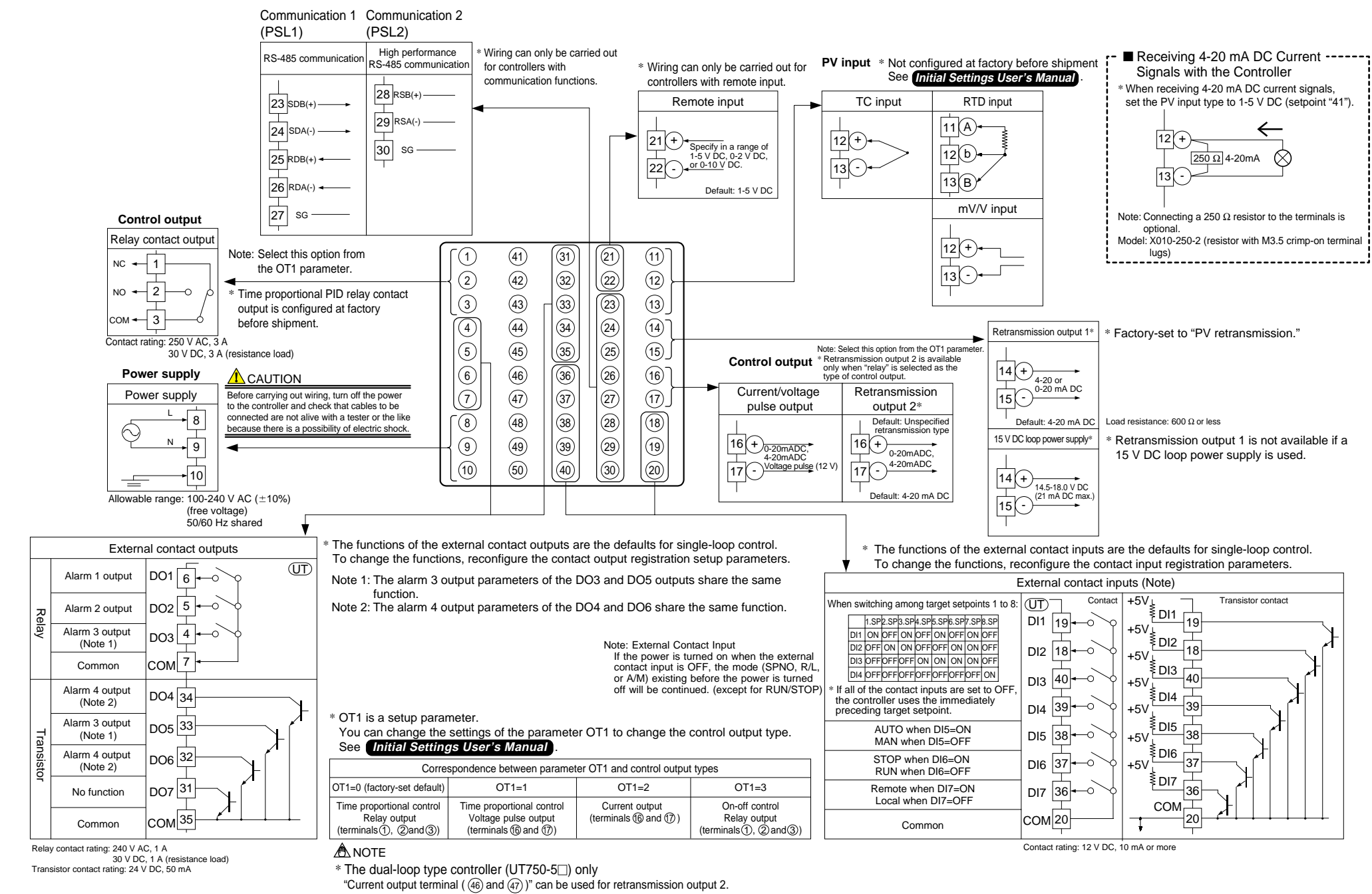

UT750 Single-loop Heating/Cooling Control (Model UT750-0□ or UT750-5□)

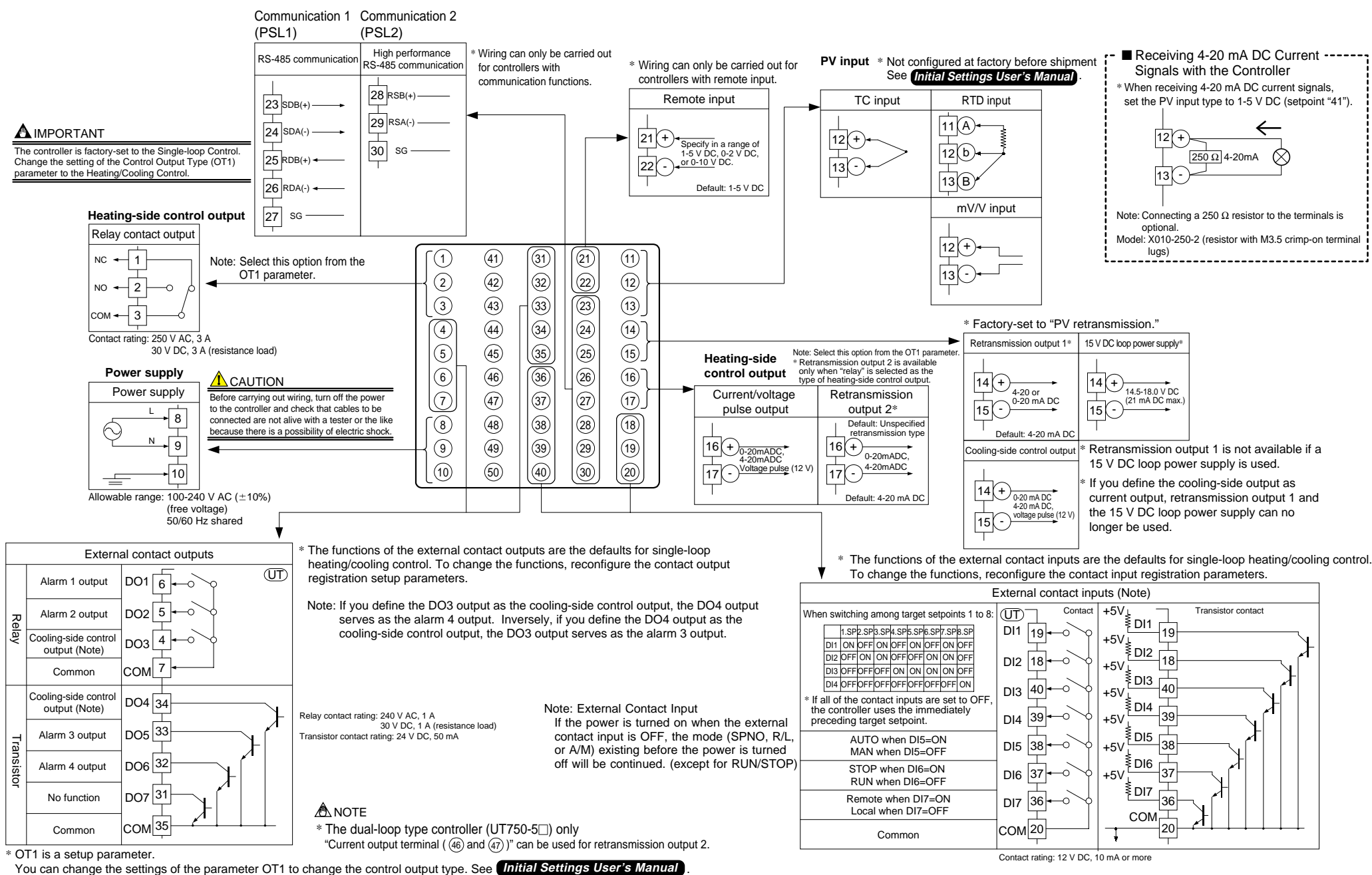

UT750 Single-loop Position Proportional Control (Model UT750-1□)

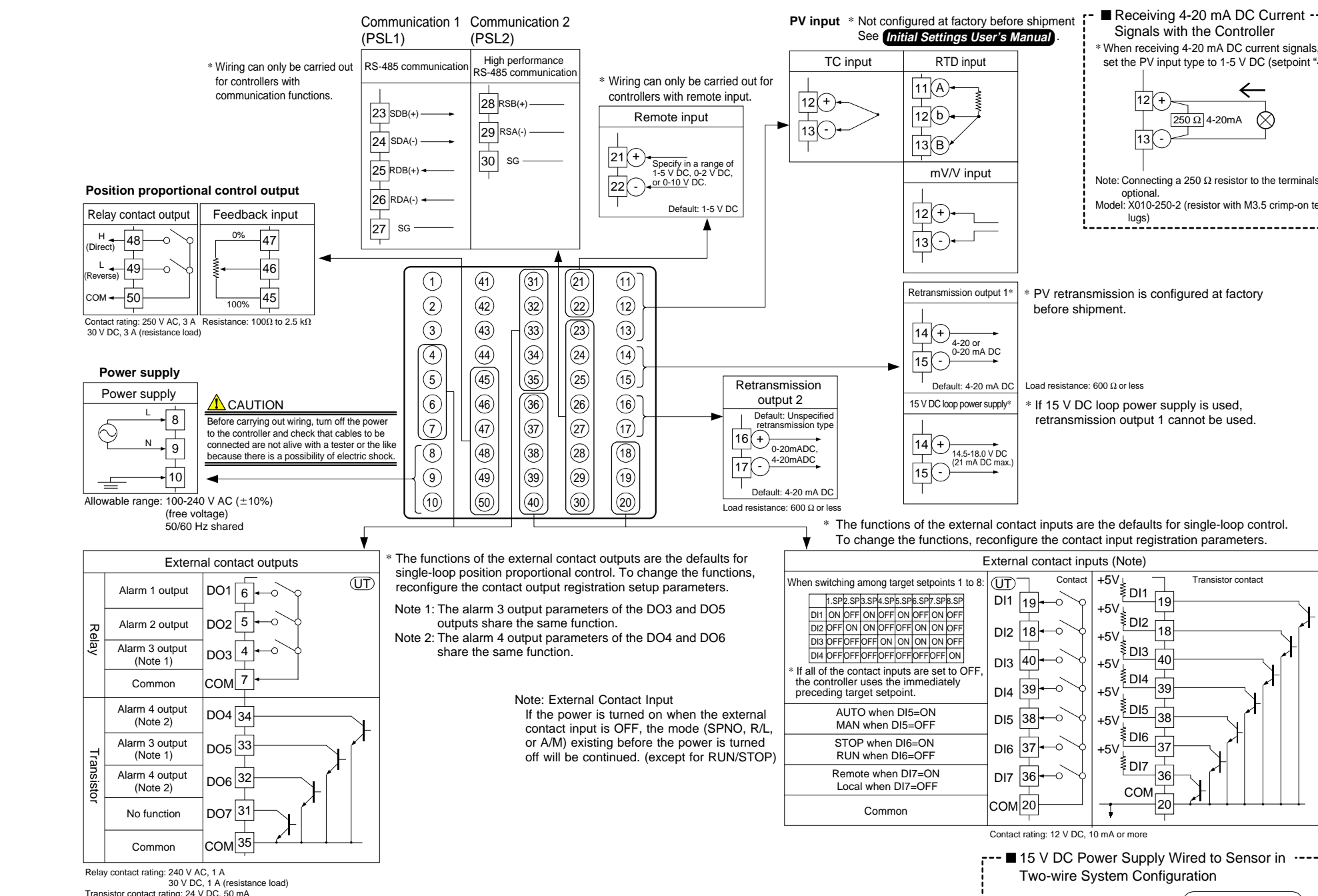

This manual describes examples of setting PV input types, control output types, and alarm types. Carrying out settings described herein allows you to perform basic control. Refer to examples of various settings to understand how to set parameters required. Refer to **Parameter Map User's Manual** for an easy to understand explanation of setting various parameters. If you cannot remember how to carry out an operation during setting, press the **DISP** key no more than four times. This brings you to the display (operating display) that appears at power-on.

Contents

- Names and Functions of Front Panel Parts
- Setting PV Input Type (Setting First at Power-on)
- Changing PV Input Type
- Setting Control Output Type (except for a Position Proportional Controller)
- Calibrating Valve Position (for a Position Proportional Controller Only)
- Initializing Parameters
- Changing Alarm Type
- Description of Multiple Setpoints and PID

1. Names and Functions of Front Panel Parts

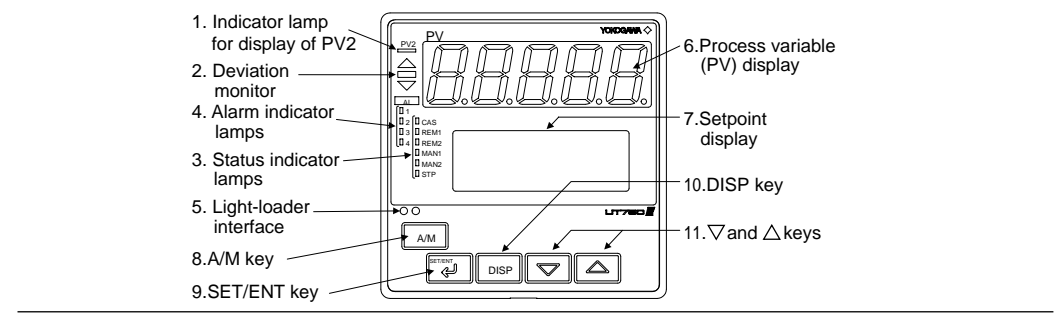

Name of Part	Function
1. Indicator lamp for display of PV2	Is lit when PV2 is displayed on PV display. Not used in single-loop control.
2. Deviation monitor	When lit, indicates the status of a deviation (PV - SP). △: Is lit (in orange) if a deviation exceeds the deviation display range. □: Is lit (in green) when a deviation is within the deviation display range. ▽: Is lit (in orange) if a deviation falls below the deviation display range. The deviation monitor goes off if any display other than the operating display or SELECT display is shown.
3. Status indicator lamps	Is lit (in green) to indicate the status of operation or control. CAS: Not used in single-loop control. REM1: Is lit when in remote mode. REM2: Not used in single-loop control. MAN1: Is lit when in manual mode. MAN2: Not used in single-loop control. STP: Is lit when operation stopped. Is unlit when a setup parameter setting display is shown.
4. Alarm indicator lamps	If any of alarms 1 to 4 occurs, the respective alarm indicator lamp (AL1 to AL4) is lit (in orange).
5. Light-loader interface	Interface for an adapter cable used when setting and storing parameters from a PC. This requires an optional parameter setting tool.
6. Process variable (PV) display	Displays PV. Displays an error code (in red) if an error occurs.
7. Setpoint display	Displays the name and value of a target setpoint (SP), output (OUT), deviation (DV), deviation trend, valve opening, or a parameter. Displays an error code if the controller fails.
8. A/M key	Used to switch between the AUTO and MAN modes. Each time you press the key, it switches to the AUTO or MAN mode alternately.
9. SET/ENT key	Used to switch or register a parameter. Pressing the key for more than 3 second allows you to switch between the operating display and the main menu for operating parameter setting display alternately. Used to switch between displays. Pressing this key while any operating display is shown lets you switch to another prearranged operating display. Pressing this key while any display other than an operating display is shown lets you go back one display. (One to four presses (maximum) of this key lets you return to the current operating display, though the number of presses depends on the operating status.)
10. DISP key	Used to change numerical values. On setup displays for various parameters, you can change target setpoints, parameters, and output values (in manual operation). Pressing the ▽ key decreases a numerical value, while pressing the △ key causes it to increase. You can hold down a key to gradually increase the speed of change. These keys also switch between menu displays when a main menu or submenu of parameter setting display is shown.
11. ▽ and △ keys	Used to change numerical values. On setup displays for various parameters, you can change target setpoints, parameters, and output values (in manual operation). Pressing the ▽ key decreases a numerical value, while pressing the △ key causes it to increase. You can hold down a key to gradually increase the speed of change. These keys also switch between menu displays when a main menu or submenu of parameter setting display is shown.

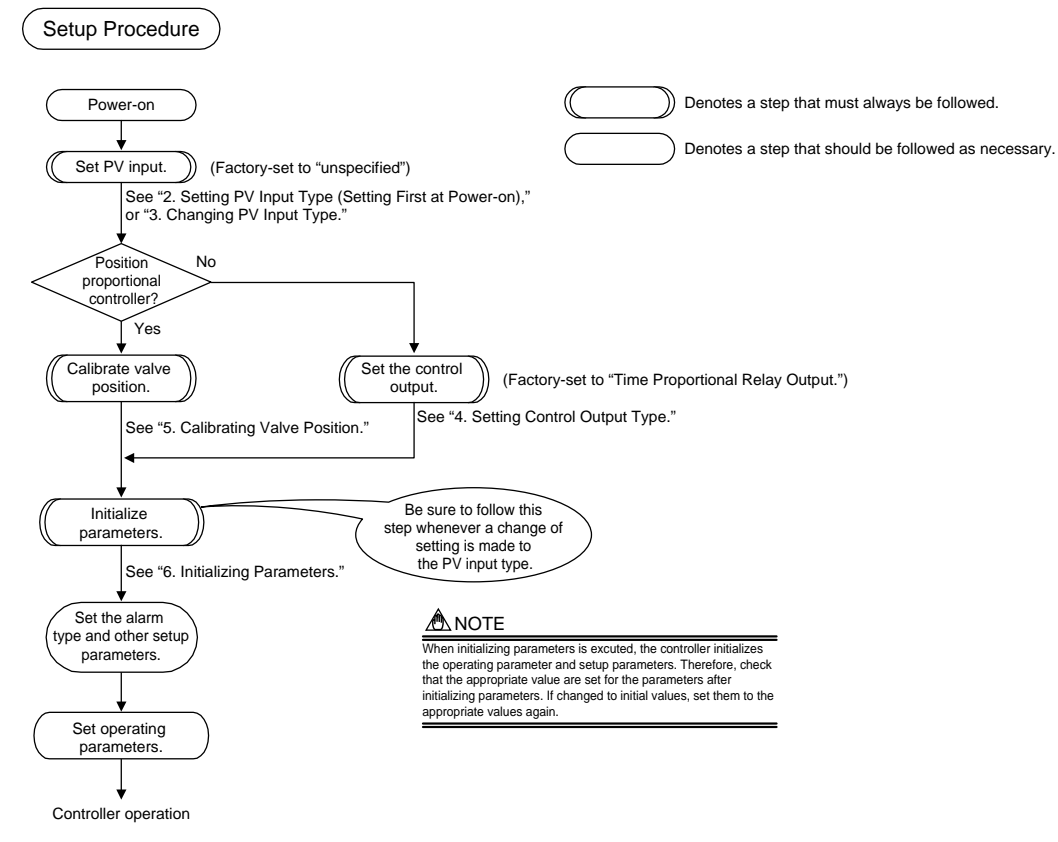

NOTE
 When initializing parameters is executed, the controller initializes the operating parameter and setup parameters. Therefore, check that the appropriate value are set for the parameters after initializing parameters. If changed to initial values, set them to the appropriate values again.

Setting of Main Parameters at the Factory before Shipment

Item	Factory-set defaults for single-loop type/dual-loop type controllers	Factory-set defaults for position proportional type controllers
	Remote input signal (only for controllers with remote inputs)	1 to 5 V DC (variable)
Control output	Time proportional PID relay output (variable)	Relay output (fixed)
Control action	Reverse action (variable)	Not specified
PID parameter	P = 5.0%, I = 240 seconds, D = 60 seconds.	
Alarm output	Alarm-1: PV high limit, Alarm-2: PV low limit, Alarm-3: PV high limit, Alarm-4: PV low limit	

2. Setting PV Input Type (Setting First at Power-on)

NOTE

- The controller displays an operating display when the power is turned on. The submenu "IN" appears at this point if the type of PV input has not been defined yet. In this case, first press the **DISP** key once to display the parameter "UN1" for the PV input type. Then, set the maximum value (RH1) and minimum value (RL1) of the PV input range (for voltage input, set the maximum value (SH1) and minimum value (SL1) of the PV input scale). Press the **DISP** key to register the settings. See the operating procedure below for more details.
- The controller is configured to the default of each parameter at the factory before shipment. First check these defaults listed in **Parameters User's Manual** and change their values if necessary.

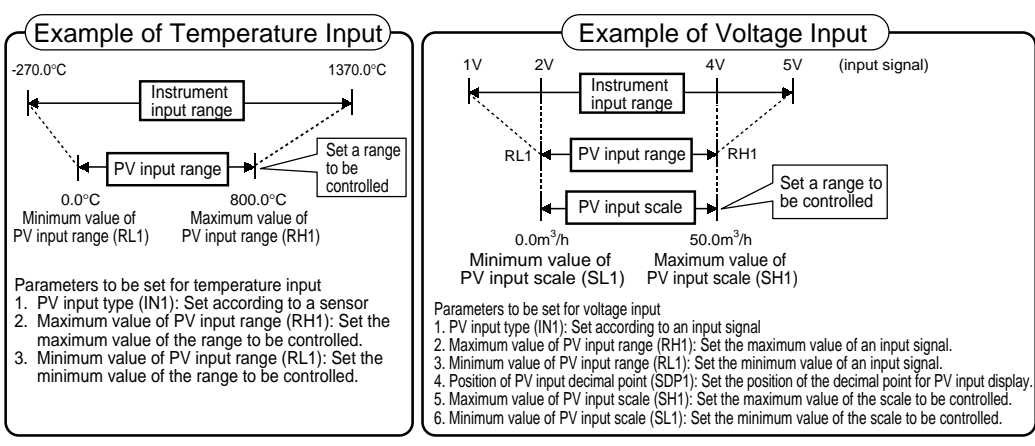

The following operating procedure describes an example of setting a K-type thermocouple (-200.0 to 500.0°C) and a measurement range of 0.0 to 200.0°C.

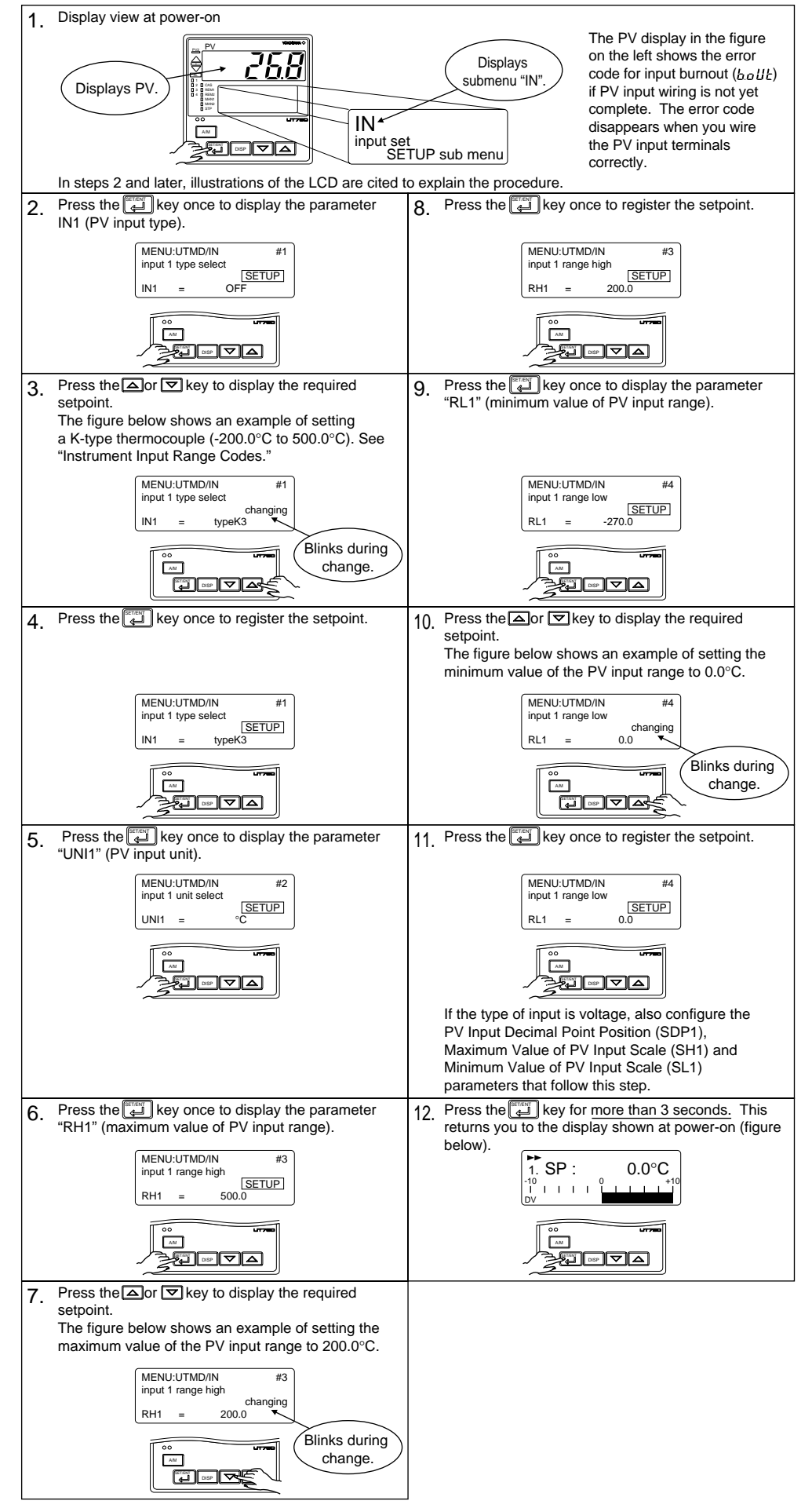

Instrument Input Range Codes

Input	Type	Instrument Input Range Code	Instrument Input Range	Measurement Accuracy	
Thermocouple	K	typeK1	-270.0 to 1370.0°C -450.0 to 2500.0°F	±0.1% of instrument range ±1 digit at 0°C or more ±0.2% ±1 digit for temperatures below 0°C, where the accuracy is: ±2% of instrument range ±1 digit for temperatures below -200.0°C for a type-K thermocouple, or ±1% of instrument range ±1 digit for temperatures below -200.0°C for a type-T thermocouple.	
		typeK2	-270.0 to 1000.0°C -450.0 to 2300.0°F		
		typeK3	-200.0 to 500.0°C -200.0 to 1000.0°F		
	J	typeJ	-200.0 to 1200.0°C -300.0 to 2300.0°F		
		typeT	-270.0 to 400.0°C -450.0 to 750.0°F		
	T	typeT1	0.0 to 400.0°C 32 to 3300°F		
		typeT2	-200.0 to 750.0°F		
	B	typeB	0.0 to 1800.0°C 32 to 3300°F		
		typeS	0.0 to 1700.0°C 32 to 3100°F		
	R	typeR	0.0 to 1700.0°C 32 to 3100°F		
		typeN	-200.0 to 1300.0°C -300.0 to 2400.0°F		
	RTD	N	typeN		-200.0 to 1300.0°C -300.0 to 2400.0°F
typeE			-270.0 to 1000.0°C -450.0 to 1800.0°F		
L(DIN)		typeL	-200.0 to 900.0°C -300.0 to 1600.0°F	±0.1% of instrument range ±1 digit at 0°C or more ±0.2% ±1 digit for temperatures below 0°C, where the accuracy is: ±1.5% of instrument range ±1 digit for temperatures below -200.0°C for a type-E thermocouple.	
		typeU1	-200.0 to 400.0°C -300.0 to 750.0°F		
U(DIN)		typeU1	0.0 to 400.0°C -200.0 to 1000.0°F	±0.2% of instrument range ±1 digit	
		typeU2	0.0 to 400.0°C -200.0 to 1000.0°F		
W		typeW	0.0 to 2300.0°C 32 to 4200°F	±0.2% of instrument range ±1 digit	
		Plati2	0.0 to 1300.0°C 32 to 2500.0°F		
Plati2		Plati2	0.0 to 1900.0°C 32 to 3400°F	±0.1% of instrument range ±1 digit No accuracy is guaranteed at less than 800°C	
		PR20-40	0.0 to 1900.0°C 32 to 3400°F		
W97Re3- W75Re25		W97Re3	0.0 to 2000.0°C 32 to 3600°F	±0.2% of instrument range ±1 digit	
		W75Re25	0.0 to 2000.0°C 32 to 3600°F		
JPt100	JPt1	-200.0 to 500.0°C -300.0 to 1000.0°F	±0.1% of instrument range ±1 digit (Note1) (Note2)		
	JPt2	-150.00 to 150.00°C -200.0 to 300.0°F			
Pt100	Pt1	-200.0 to 850.0°C -300.0 to 1560.0°F	±0.1% of instrument range ±1 digit (Note1) (Note2)		
	Pt2	-200.0 to 500.0°C -300.0 to 1000.0°F			
Pt100	Pt3	-150.00 to 150.00°C -200.0 to 300.0°F	±0.2% of instrument range ±1 digit (Note1)		
	Pt3	-150.00 to 150.00°C -200.0 to 300.0°F			
Standard signal	0.4 to 2 V	0.4 to 2 V	0.400 to 2.000 V	±0.1% of instrument range ±1 digit Display range is scalable in a range of -19999 to 30000. Display span is 30000 or less.	
	1 to 5 V	1 to 5 V	1.000 to 5.000 V		
DC voltage	0 to 2 V	0 to 2 V	0.000 to 2.000 V	±0.1% of instrument range ±1 digit Display range is scalable in a range of -19999 to 30000. Display span is 30000 or less.	
	0 to 10 V	0 to 10 V	0.00 to 10.00 V		
DC voltage	0.0 to 1.25 V (Note 3)	0.0 to 1.25 V	0.000 to 1.250 V	±0.1% of instrument range ±1 digit Display range is scalable in a range of -19999 to 30000. Display span is 30000 or less.	
	-10 to 20 mV	mV1	-10.000 to 20.000 mV		
DC voltage	0 to 100 mV	mV2	0.0 to 100.0 mV	±0.1% of instrument range ±1 digit Display range is scalable in a range of -19999 to 30000. Display span is 30000 or less.	
	0 to 100 mV	mV2	0.0 to 100.0 mV		

* Performance in the standard operating conditions (at 23 ± 2°C, 55 ± 10%RH, and 50/60 Hz power frequency)
 Note1: The accuracy is ±0.3°C of instrument range ±1 digit for a temperature range from 0°C to 100°C.
 Note2: The accuracy is ±0.5°C of instrument range ±1 digit for a temperature range from -100°C to 200°C.
 Note3: Note used in single-loop control.
 * To receive a 4-20 mA DC signal, select a standard signal of 1 to 5 V DC and connect it to a 250Ω resistor. This resistor is optional.
 Model: X010-250-2 (resistor with M3.5 crimp-on terminal lugs)

NOTE
 The controller may automatically initialize the registered operating parameter setpoints if any change is made to the data item PV Input Type (IN1), Maximum Value of PV Input Range (RH1), Minimum Value of PV Input Range (RL1), PV Input Decimal Point Position (SDP1), Maximum Value of PV Input Scale (SH1) or Minimum Value of PV Input Scale (SL1). After a change has been made to any of these data items, be sure to verify the registered operating parameter setpoints to ensure that they are correct. If any data item has been changed to its default, set it to a required value.

Ranges Selectable for PV Input

Thermocouple	typeK1, K2, K3, J, T1, T2, B, S, R, N, E, L, U1, U2, W, Plati2, PR2040
RTD	JPt1, JPt2, Pt1, Pt2, Pt3, Pt4
DC voltage(mV,V)	0.4 to 2 V, 1 to 5 V, 0 to 2 V, 0 to 10 V, mV1, mV2

Ranges Selectable for Remote Input

DC voltage(V)	0.4 to 2 V, 1 to 5 V, 0 to 2 V, 0 to 10 V
---------------	---

How to return to a menu
 Press **DISP** key once during parameter setting. This lets you return to the parameter menu.

3. Changing PV Input Type

The following operating procedure describes an example of changing the setting of K-type thermocouple (-200.0 to 500.0°C) to RTD Pt100 (-200.0 to 500.0°C) and a measurement range of 0.0 to 200.0°C.

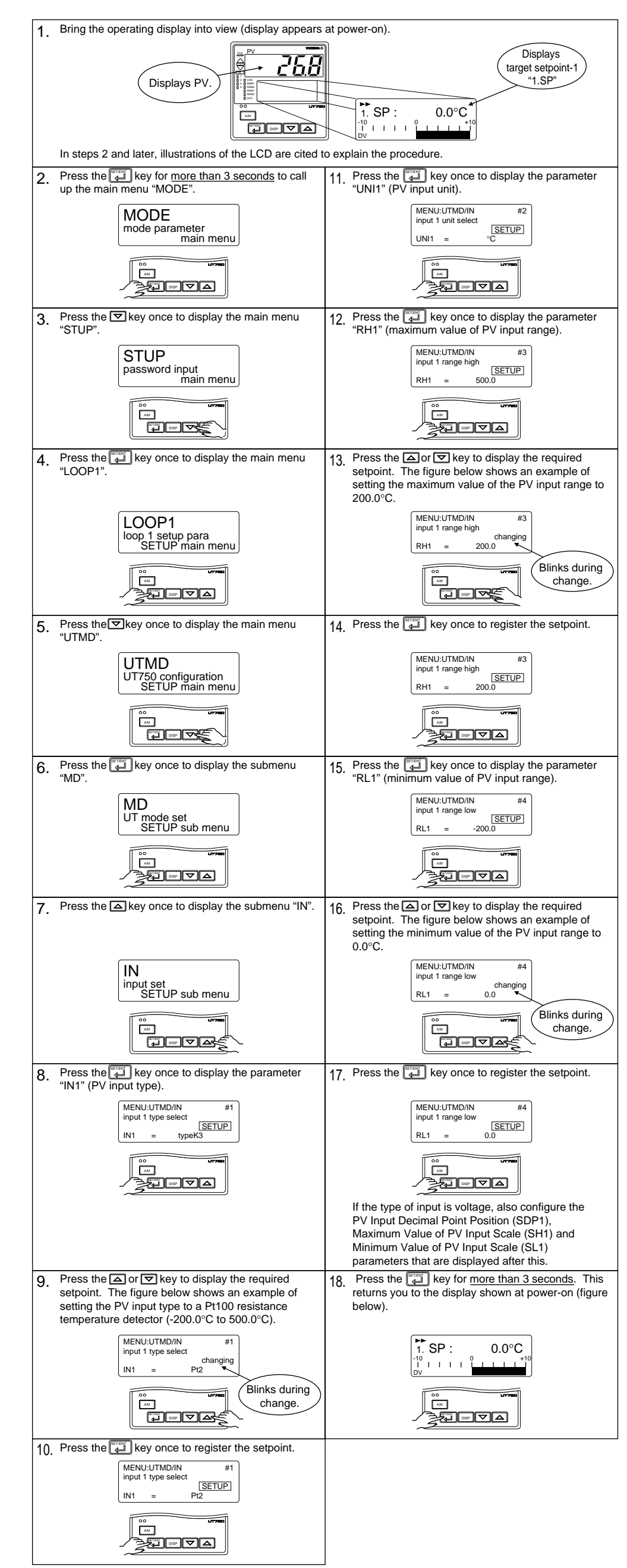

4. Setting Control Output Type (except for a Position Proportional Controller)

The following operating procedure describes an example of changing time proportional PID relay output (0: factory-set default) to current output (2).

Control output terminal Values in parentheses are setpoints
 Time proportional PID relay (0)/on-off(3) output.....①-②-③
 Current (2)/time proportional PID voltage pulse (1) output.....④-⑦
 For details on the output terminals for heating/cooling control, see "6. Terminal Wiring Diagrams" in the **Installation User's Manual**.

- Bring the operating display into view (display appears at power-on).
- Press the **[F4]** key for more than 3 seconds to call up the main menu "MODE".
- Press the **[F1]** key once to display the main menu "STUP".
- Press the **[F4]** key once to display the main menu "LOOP1".
- Press the **[F1]** key once to display the main menu "UTMD".
- Press the **[F2]** key once to display the submenu "MD".
- Press the **[F1]** key for more than 3 seconds to call up the main menu "MODE".
- Press the **[F2]** key twice to display the submenu "OUT".
- Press the **[F1]** key once to display the parameter "OT1" (control output type).
- Press the **[F4]** or **[F5]** key to display the required setpoint. The figure below shows an example of setting to current output (4 to 20 mA DC).
- Press the **[F1]** key once to register the setpoint. This returns you to the display shown at power-on (figure below).

List of Control Output Types

Parameter Symbol	Name of Parameter	Setpoint	Control Output Types
OT1	Control output type	0	Time proportional PID relay contact output (terminals ①-②-③)
		1	Time proportional PID voltage pulse output (terminals ④-⑦)
		2	Current output (terminals ⑧-⑩)
		3	On/off control relay contact output (terminals ①-②-③)
		4	Heating-side relay output (terminals ①-②-③), cooling-side relay output (terminals ④-⑦)
		5	Heating-side pulse output (terminals ⑧-⑩), cooling-side relay output (terminals ①-⑦)
		6	Heating-side current output (terminals ⑧-⑩), cooling-side relay output (terminals ①-⑦)
		7	Heating-side relay output (terminals ①-②-③), cooling-side transistor output (terminals ④-⑦)
		8	Heating-side pulse output (terminals ⑧-⑩), cooling-side transistor output (terminals ④-⑦)
		9	Heating-side current output (terminals ⑧-⑩), cooling-side transistor output (terminals ④-⑦)
		10	Heating-side relay output (terminals ①-②-③), cooling-side current output (terminals ④-⑦)
		11	Heating-side pulse output (terminals ⑧-⑩), cooling-side current output (terminals ④-⑦)
12	Heating-side current output (terminals ⑧-⑩), cooling-side current output (terminals ④-⑦)		

5. Calibrating Valve Position (for a Position Proportional Controller Only)

The following operation describes a procedure of inputting a feedback signal from a control valve to calibrate the full closed and full open positions of the valve automatically. To calibrate the valve position, you need to carry out wire connections and bring the controller into manual mode. For connections, see "6. Terminal Wiring Diagrams" in the **Installation User's Manual** and for entering the manual mode, see "8. Switching between AUTO and MAN" in **Operations User's Manual**.

- Bring the operating display into view (display appears at power-on).
- Press the **[F4]** key for more than 3 seconds to call up the main menu "MODE".
- Press the **[F1]** key once to display the main menu "STUP".
- Press the **[F4]** key once to display the main menu "LOOP1".
- Press the **[F1]** key once to display the main menu "UTMD".
- Press the **[F2]** key once to display the submenu "MD".
- Press the **[F1]** key three times to display the submenu "VALV".
- Press the **[F1]** key once to display the parameter "VAT".
- Press the **[F1]** key for more than 3 seconds to call up the main menu "MODE".
- Press the **[F2]** key to display "ON".
- Press the **[F1]** key once. The controller automatically calibrates the valve position (fully open or closed).
- The controller is viewed as shown below when the valve position is being automatically calibrated.
- Calibration has ended successfully when the indication changes from "ON" to "OFF".

 Go to step [14].
- Calibration has ended unsuccessfully if the indication changes from "ON" to "ERR". Check the feedback input wiring and carry out automatic calibration again.
- Press the **[F1]** key for more than 3 seconds. This returns you to the display shown at power-on (figure below).

6. Initializing Parameters

Be sure to follow the steps below after a change of setting has been made to the data item PV Input Type, PV Input Range or PV Input Scale.

CAUTION

Initializing the above parameter setpoints may initialize the registered operating/setup parameter setpoints. Check that they are correct. If any of them has been changed to its initial value, set it to a required value.

- Bring the operating display into view (display appears at power-on).
- Press the **[F4]** key for more than 3 seconds to call up the main menu "MODE".
- Press the **[F1]** key once to display the main menu "STUP".
- Press the **[F4]** key once to display the main menu "LOOP1".
- Press the **[F1]** key once to display the main menu "UTMD".
- Press the **[F2]** key once to display the submenu "MD".
- Press the **[F1]** key for more than 3 seconds to call up the main menu "MODE".
- Press the **[F2]** key twice to display the submenu "INIT".
- Press the **[F1]** key once to display the main menu "STUP".
- Press the **[F1]** key once to display the parameter "INI".
- Press the **[F4]** key once to display the main menu "LOOP1".
- Press the **[F1]** key for more than 3 seconds to call up the main menu "MODE".
- Press the **[F2]** key twice to display the submenu "INIT".
- Press the **[F1]** key once to display the main menu "STUP".
- Press the **[F1]** key once to display the parameter "INI".
- Press the **[F1]** key once to display the main menu "UTMD".
- Press the **[F1]** key once. The display momentarily becomes blank (which is normal), indicating the parameters have been initialized.
- Press the **[F2]** key once to display the submenu "MD".
- Press the **[F1]** key for more than 3 seconds. This returns you to the display shown at power-on (figure below).

7. Changing Alarm Type

The following operating procedure describes an example of changing alarm 1 (factory-set to the PV high limit alarm) to the PV low limit alarm. When you have changed alarm type, the alarm setpoint will be initialized; set the alarm setpoint again.

Alarm output terminals Factory-set defaults
 Alarm-1 (terminal numbers ⑧-⑩).....PV high limit alarm
 Alarm-2 (terminal numbers ③-⑦).....PV low limit alarm
 Alarm-3 (terminal numbers ③-⑦).....PV high limit alarm
 Alarm-4 (terminal numbers ⑧-⑩).....PV low limit alarm

- Bring the operating display into view (display appears at power-on).
- Press the **[F4]** key for more than 3 seconds to call up the main menu "MODE".
- Press the **[F1]** key once to display the main menu "STUP".
- Press the **[F4]** key once to display the main menu "LOOP1".
- Press the **[F1]** key once to display the submenu "SP".
- Press the **[F2]** key once to display the submenu "ALM".
- Press the **[F1]** key once to display the parameter "AL1" (alarm-1 type).

- Press the **[F4]** or **[F5]** key to display the required setpoint. The figure below shows an example of setting the PV low limit alarm.
- Press the **[F1]** key for more than 3 seconds. This returns you to the display shown at power-on (figure below).
- Press the **[F1]** key once to register the setpoint.
- When setting alarm setpoints, see "5. Setting Alarm Setpoints" in **Operations User's Manual**.

List of Alarm Types

The table below shows the alarm types and alarm actions. In the table, codes 1 to 10 are not provided with stand-by actions, while codes 11 to 20 are provided with stand-by actions.

Alarm type	Alarm action	Alarm type code	Alarm type	Alarm action	Alarm type code	
No alarm	"Open/close" shows status of relay contact, and "lit" and "unlit" shows status of lamp	OFF				
PV high limit	Hysteresis Open (unlit) → Closed (lit) Alarm setpoint	1 11	De-energized on deviation low limit alarm	Hysteresis Open (lit) → Closed (unlit) Deviation setpoint Target SP	6 16	
PV low limit	Hysteresis Closed (lit) → Open (unlit) Alarm setpoint	2 12	Deviation high and low limits	Hysteresis Closed (lit) → Open (unlit) Deviation setpoint Target SP	7 17	
Deviation high limit	Hysteresis Open (unlit) → Closed (lit) Target SP	3 13	Deviation within high and low limits	Hysteresis Open (unlit) → Closed (lit) Deviation setpoint Target SP	8 18	
Deviation low limit	Hysteresis Closed (lit) → Open (unlit) Deviation setpoint	4 14	De-energized on PV high limit	Hysteresis Closed (unlit) → Open (lit) Alarm setpoint	9 19	
De-energized on deviation high limit alarm	Hysteresis Closed (unlit) → Open (lit) Target SP	5 15	De-energized on PV low limit	Hysteresis Open (lit) → Closed (unlit) Alarm setpoint	10 20	
Timer function (control stability report event) (Alarm-1 only)	Upward (hour/minute)	21	Sensor grounding alarm	Sensor grounding alarm	25	
	Downward (hour/minute)	22		Fault diagnosis output (Note1)	26	
	Upward (minute/second)	23		FAIL output (Note2)	The controller stops when in a FAIL state. The control output is set to "OFF" or "0%" and the alarm output is set to "OFF".	27
	Downward (minute/second)	24				
SP high limit	Hysteresis Open (unlit) → Closed (lit) SP	28	Output high limit	Hysteresis Open (unlit) → Closed (lit) Output value	30	
SP low limit	Hysteresis Closed (lit) → Open (unlit) Alarm setpoint	29	Output low limit	Hysteresis Closed (lit) → Open (unlit) Alarm setpoint	31	

Note 1: The fault diagnosis output turns on in case of input burnout, A/D converter failure, or reference junction compensation (RJC) failure. For input burnout or A/D converter failure, the control output is set to the setpoint of the Preset Output Value operating parameter (PO).

Note 2: The FAIL output is on during normal operation and turns off in case of failure.

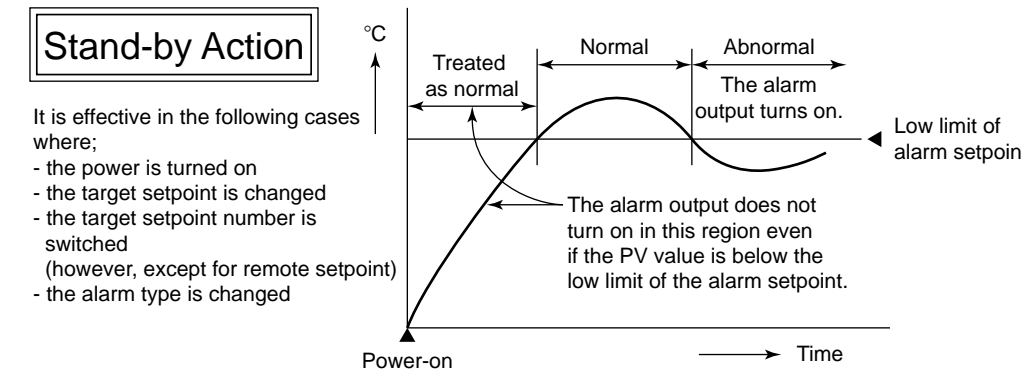

8. Description of Multiple Setpoints and PID

The UT750 has a maximum of eight target setpoints, and has PID for each of these setpoints. The following shows the correspondence between the target setpoint numbers (SPNO), target setpoints (SP), and PID parameters. For example, if you have set "2" to the target setpoint number (SPNO), the control parameters available are target setpoint (2.SP), proportional band (heating-side proportional band) (2.P), integral time (heating-side integral time) (2.I), derivative time (heating-side derivative time) (2.D), cooling-side proportional band (2.Pc), cooling-side integral time (2.Ic), and cooling-side derivative time (2.Dc).

To use multiple target setpoints, see the table below to check the corresponding parameters.

Target setpoint number (SPNO)	Target setpoint (SP)	PID parameter					
		Proportional band (heating-side proportional band)	Integral time (heating-side integral time)	Derivative time (heating-side derivative time)	Cooling-side proportional band	Cooling-side integral time	Cooling-side derivative time
SPNO=1	1.SP	1.P	1.I	1.D	1.Pc	1.Ic	1.Dc
SPNO=2	2.SP	2.P	2.I	2.D	2.Pc	2.Ic	2.Dc
SPNO=3	3.SP	3.P	3.I	3.D	3.Pc	3.Ic	3.Dc
SPNO=4	4.SP	4.P	4.I	4.D	4.Pc	4.Ic	4.Dc
SPNO=5	5.SP	5.P	5.I	5.D	5.Pc	5.Ic	5.Dc
SPNO=6	6.SP	6.P	6.I	6.D	6.Pc	6.Ic	6.Dc
SPNO=7	7.SP	7.P	7.I	7.D	7.Pc	7.Ic	7.Dc
SPNO=8	8.SP	8.P	8.I	8.D	8.Pc	8.Ic	8.Dc

This manual describes key entries for operating the controller. For operations using external contact inputs, see "6. Terminal Wiring Diagrams" in **Installation User's Manual**. If you cannot remember how to carry out an operation during setting, press the **[DSP]** key no more than four times. This brings you to the display (operating display) that appears at power-on.

Contents

- Monitoring-purpose Operating Displays Available during Operation
- Setting Target Setpoint (SP)
- Performing/Canceling Auto-tuning
- Setting PID Manually
- Setting Alarm Setpoints
- Selecting Target Setpoint Numbers (SPNO)
- Switching between Run and Stop
- Switching between AUTO and MAN
- Manipulating Control Output during Manual Operation
- Switching between Remote (REM) and Local (LCL)
- Troubleshooting

1. Monitoring-purpose Operating Displays Available during Operation

The monitoring-purpose operating displays available during operation include those for single-loop and single-loop position proportional control and those for single-loop heating/cooling control. The Process Variable (PV) display always shows the value of PV input.

Operating Displays for Single-loop and Single-loop Position Proportional Control

- SP Display**
On the Setpoint display (LCD), the controller displays the target setpoint (SP), along with the deviation bar.
- OUT Display**
On the Setpoint display (LCD), the controller displays the target setpoint, PID number, and control output value, along with the control output bar.
For position proportional control, the valve opening (0 to 100%) is displayed instead of the control output value.
- Deviation Trend Display**
On the Setpoint display (LCD), the controller displays the deviation trend.
- Data List Display**
On the Setpoint display (LCD), the controller displays the target setpoint, control output value, deviation, and PID number.

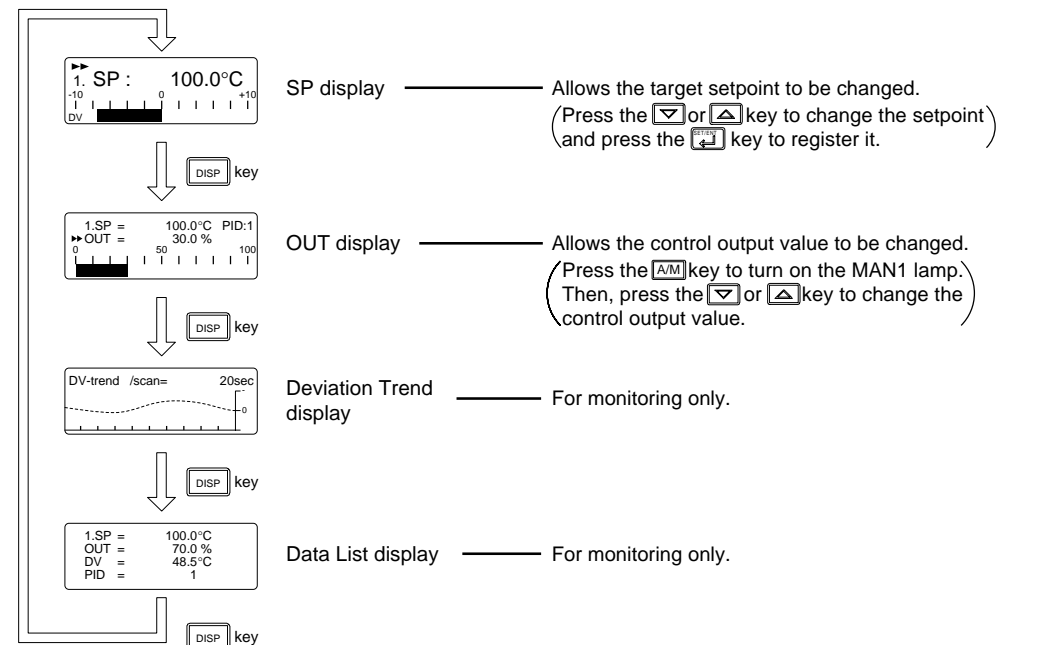

Operating Displays for Single-loop Heating/Cooling Control

- SP Display**
On the Setpoint display (LCD), the controller displays the target setpoint (SP), along with the deviation bar.
- Heating/Cooling OUT Display**
On the Setpoint display (LCD), the controller displays the target setpoint, PID number, and heating-side (HEAT) and cooling-side (COOL) control output values.
- Deviation Trend Display**
On the Setpoint display (LCD), the controller displays the deviation trend.
- Heating/Cooling Data List Display**
On the Setpoint display (LCD), the controller displays the target setpoint, heating-side (H) and cooling-side (C) control output values, deviation, and PID number.

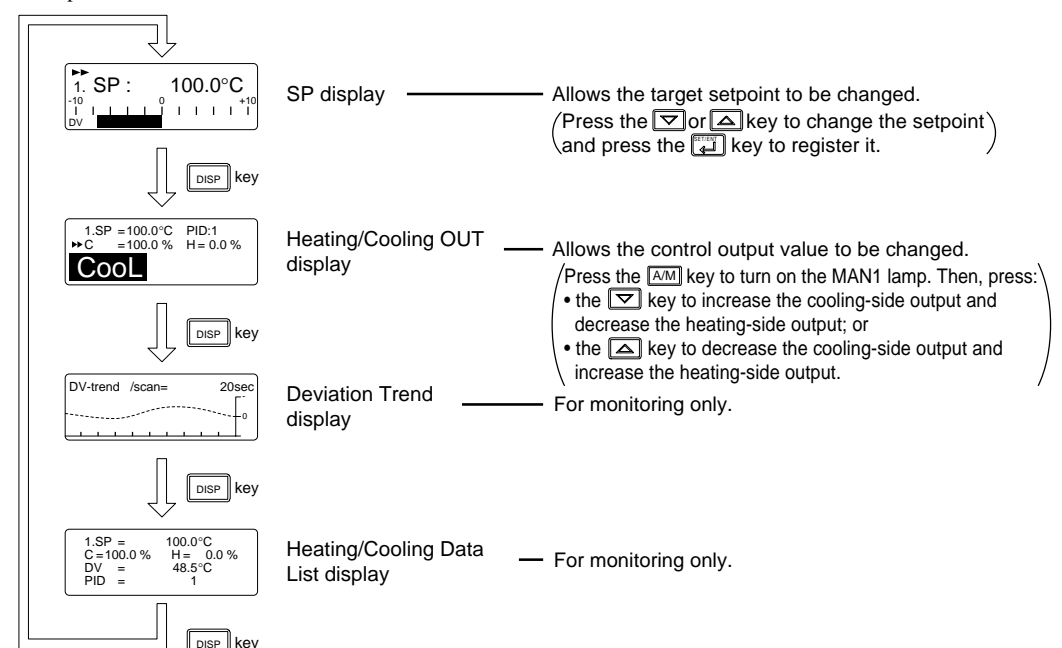

2. Setting Target Setpoint (SP)

The following operating procedure describes an example of setting 150.0 to a target setpoint. In automatic operation, the controller starts control using set target setpoints.

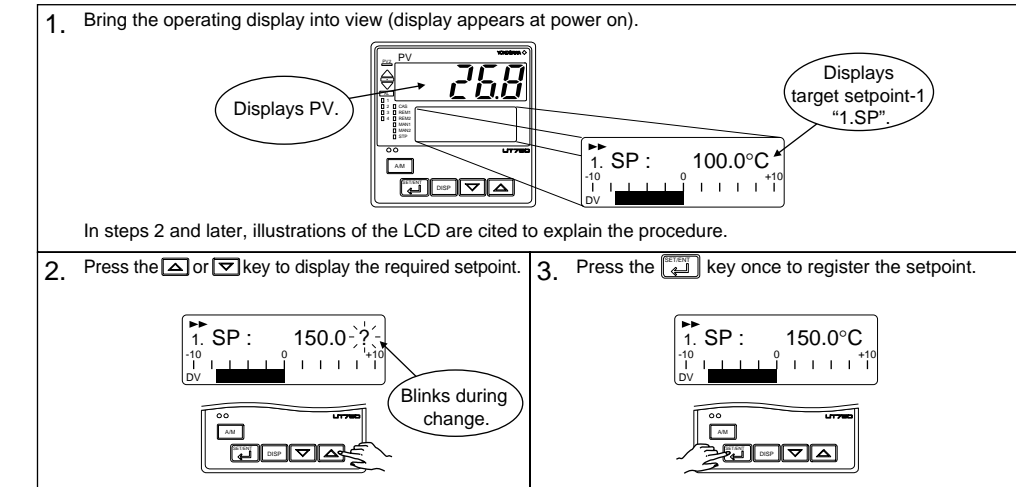

3. Performing/Canceling Auto-tuning

Auto-tuning should be carried out after setting a target setpoint (SP). Make sure the controller is in automatic operation mode (AUTO) and in running state (RUN) before carrying out auto-tuning. See "8. Switching between AUTO and MAN," to change to AUTO and "7. Switching between Run and Stop," to change to Run.

NOTE
 When on-off control is being used, auto-tuning cannot be carried out. Moreover, do not perform auto-tuning when controlling any of the following processes.
 • Control processes with quick response such as flow control or pressure control
 • Processes where even temporary output on/off results in inconvenience
 • Processes where a large output change at control element results in inconvenience
 • Processes where variations in PV may exceed an allowable range, adversely affecting product quality

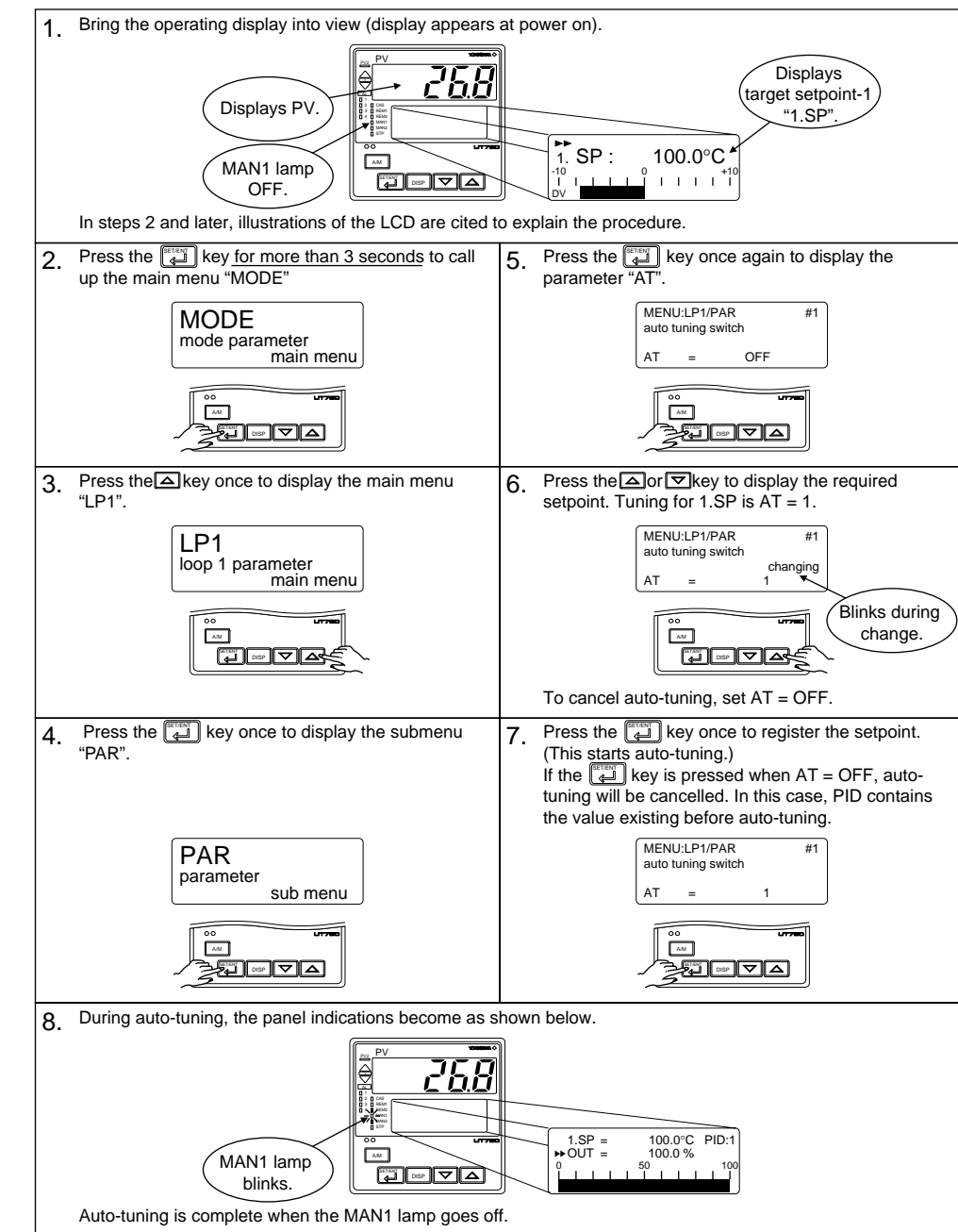

4. Setting PID Manually

If you know the values to be set or if suitable PID constants cannot be obtained by auto-tuning, follow the procedure below to set values.

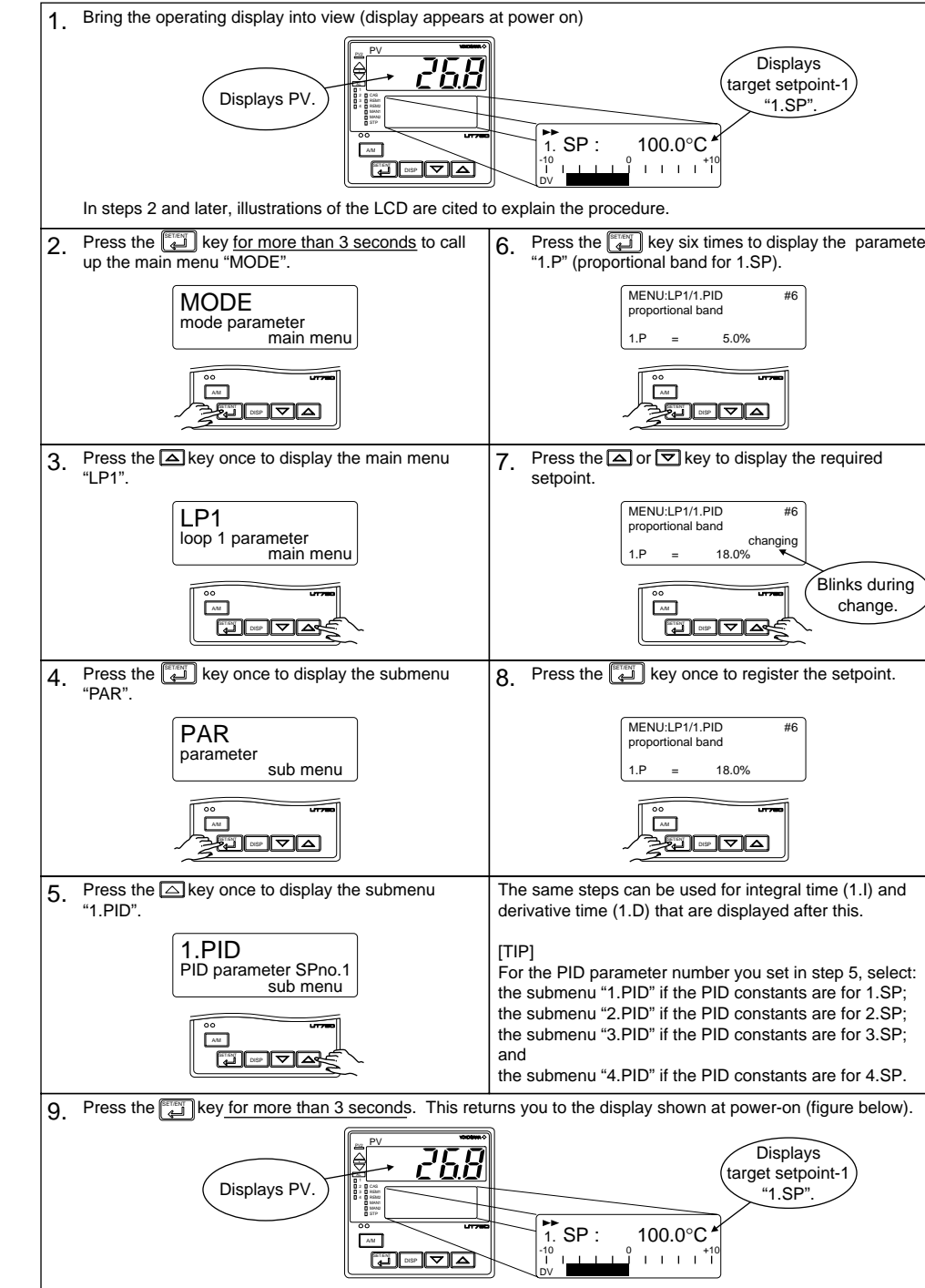

5. Setting Alarm Setpoints

The following operating procedure describes an example of setting 160.0 to alarm-1 setpoint. Check alarm type before setting the alarm setpoint.
 When changing the alarm type, see "7. Changing Alarm Type," in **Initial Settings User's Manual**.

Alarm output terminals	Factory-set defaults
Alarm-1 (terminal numbers ①-②)	PV high limit alarm
Alarm-2 (terminal numbers ③-④)	PV low limit alarm
Alarm-3 (terminal numbers ⑤-⑥)	PV high limit alarm
Alarm-4 (terminal numbers ⑦-⑧)	PV low limit alarm

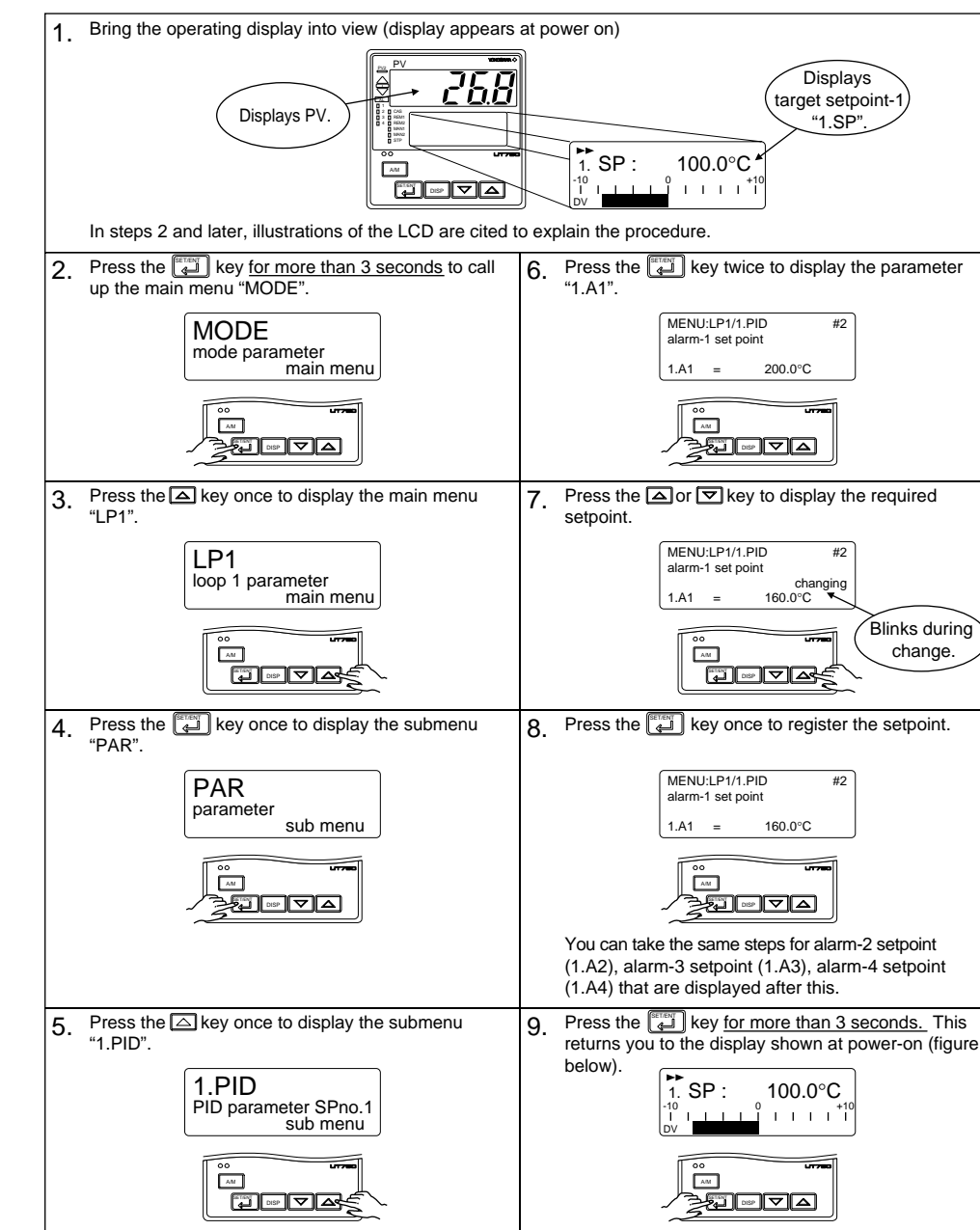

6. Selecting Target Setpoint Numbers (SPNO)

The following operating procedure describes an example of changing a target setpoint number (SPNO) from 1 to 2.
NOTE
 If a target setpoint number has been switched using contact input, when the contact input is on, that number cannot be selected by keystroke.

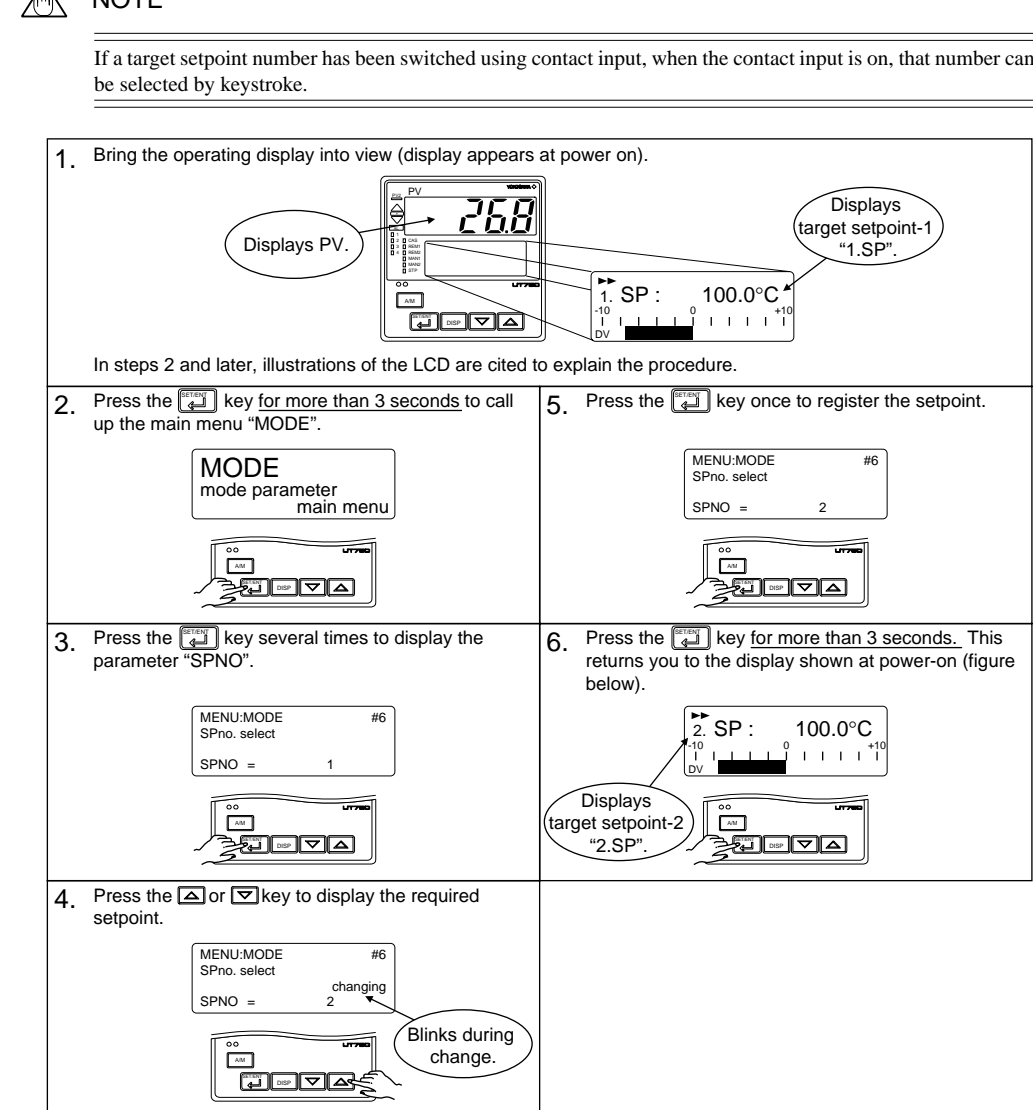

7. Switching between Run and Stop

Selection between the Run state (RUN) and Stop state (STOP) can be made with contact input 6 (DI6). (factory-set default)

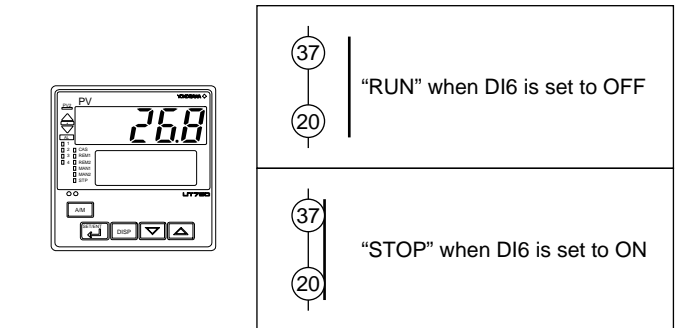

When the controller is stopped, input and outputs are as follows:
 When the controller is stopped, the STP lamp on the front panel is lit.

PV input	Displays the PV value.
Control output	Provides the preset output value (factory-set to 0%).
Alarm output	Turns the output on in case of an alarm.

8. Switching between AUTO and MAN

NOTE
If AUTO and MAN have been switched using contact input, when the contact input is ON, switching between AUTO and MAN cannot be achieved by keystroke.

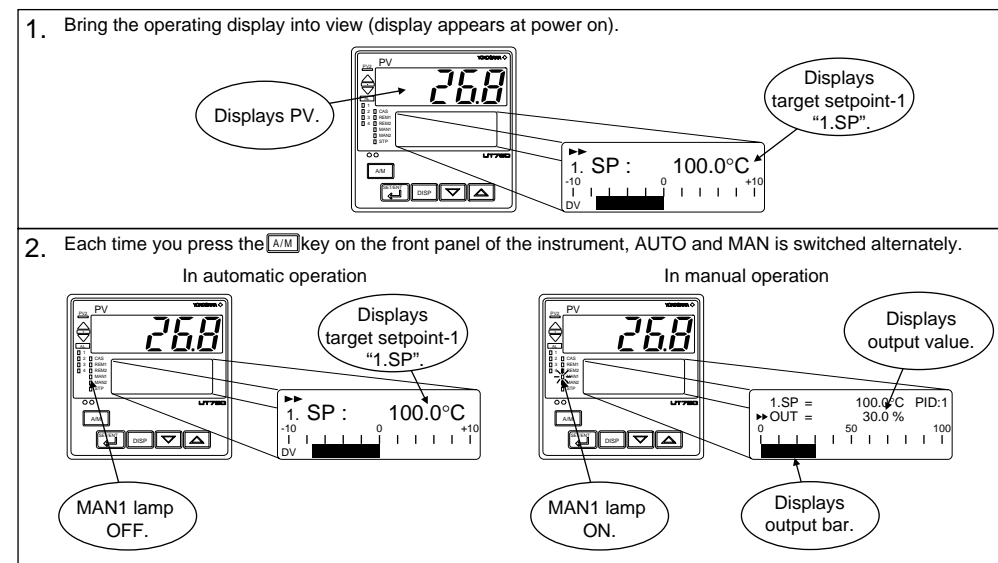

9. Manipulating Control Output during Manual Operation

NOTE
Control output cannot be changed if the controller is stopped. In this case, the preset output value (operating parameter PO) will be output. In heating/cooling control, the heating-side preset output value (operating parameter PO) and cooling-side preset output value (operating parameter Oc) will be output.

A control output value is linked with a display value changed using the key. Note that the control output changes as displayed without requiring the key.

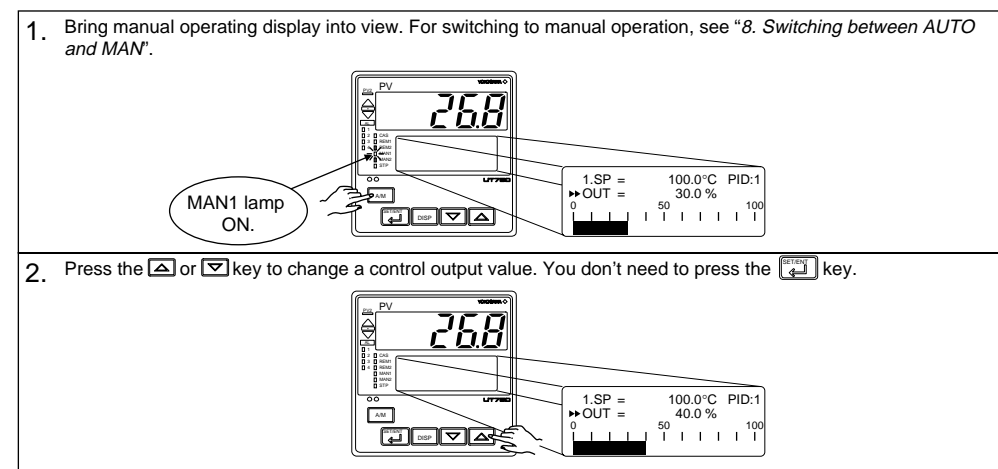

Manipulating the Control Output during Heating/Cooling Control

Showing the Heating/Cooling OUT display.

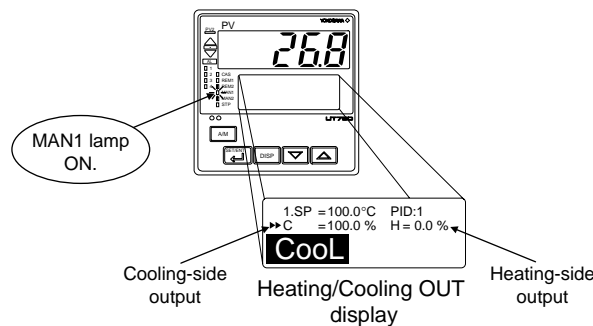

Controller behavior and control output manipulation when the dead band is positive
The following is an example when the DB parameter is set at 12.4%.
If you hold down the key with the heating-side output under manipulation (i.e., cooling-side output C = 0.0%), the heating-side output (H =) decreases.
Consequently, both the heating-side and cooling-side outputs change to 0.0%. If you keep the key held down longer, you enter the state of manipulating the cooling-side output, and its value begins to increase.
Inversely, if you hold down the key with the cooling-side output under manipulation (i.e., heating-side output H = 0.0%), the cooling-side output (C =) decreases. Consequently, both the heating-side and cooling-side outputs go to 0.0%. If you keep the key held down longer, you enter the state of manipulating the heating-side output, and its value begins to increase.

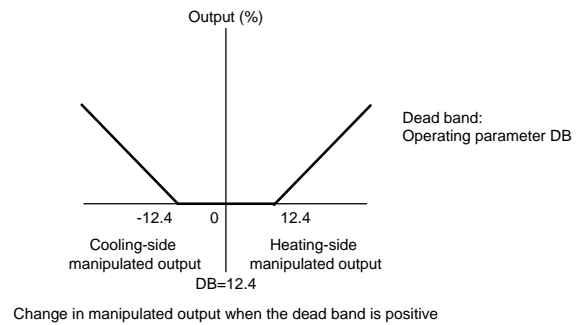

Controller behavior and control output manipulation when the dead band is negative
The following is an example when the DB parameter is set at -12.4%.
If you hold down the key with the heating-side output under manipulation (i.e., cooling-side output C = 0.0%), the heating-side output (H =) decreases. If the output H falls below 24.8%, the cooling-side output C begins to increase from 0.0%. If you keep the key held down longer and the output C rises above 24.8%, the output H goes to 0.0% and you enter the state of manipulating the cooling-side output.

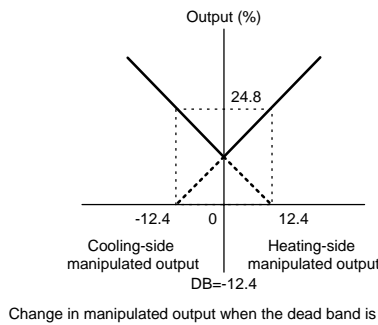

Manipulating the Control Output during Position Proportional Control

The controller continues to provide control output as long as the key or key is being pressed.
key: Closes the valve.
key: Opens the valve.

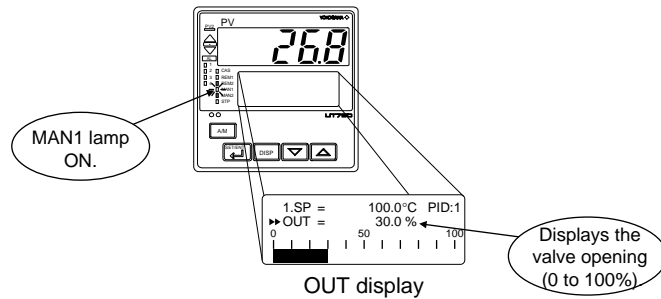

Note: Manual output is not limited to output high limit(OH) and output low limit(OL).

10. Switching between Remote (REM) and Local (LCL)

The following operating procedure describes an example of switching from Local (LCL) to Remote (REM). Switching between REM and LCL is possible for only controllers with remote input.
Local: Performs control using target setpoints set in the controller.
Remote: Performs control using external analog signals as target setpoints.

Note: The PID group number when the controller is in Remote operation is the same as the number set in the Target Setpoint Number (SPNO) parameter.

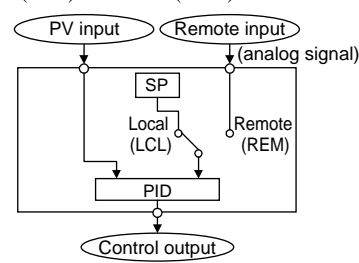

NOTE

If Remote state is achieved by external contact input (contact input is ON), switching between REM and LCL cannot be achieved by keystroke.

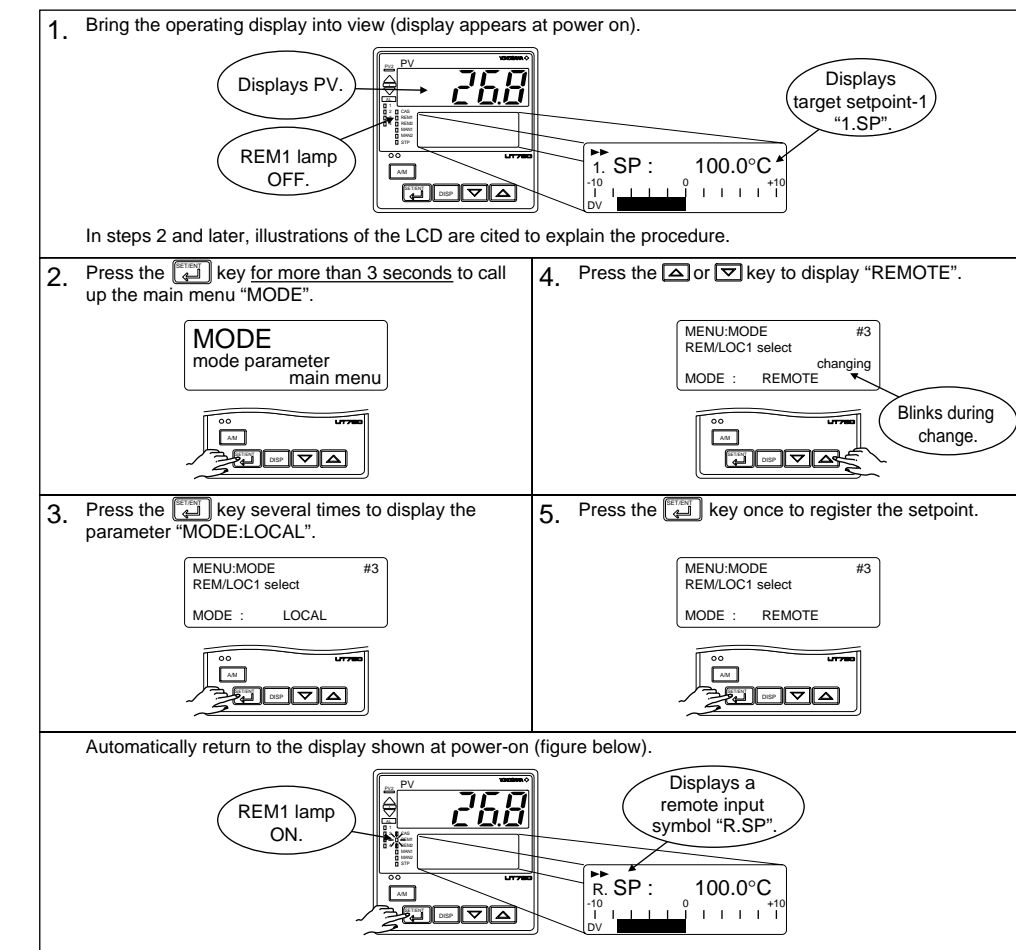

11. Troubleshooting

Troubleshooting Flow

If the operating display does not appear after turning on the controller's power, follow the measures in the procedure below. If a problem appears complicated, contact our sales representative.

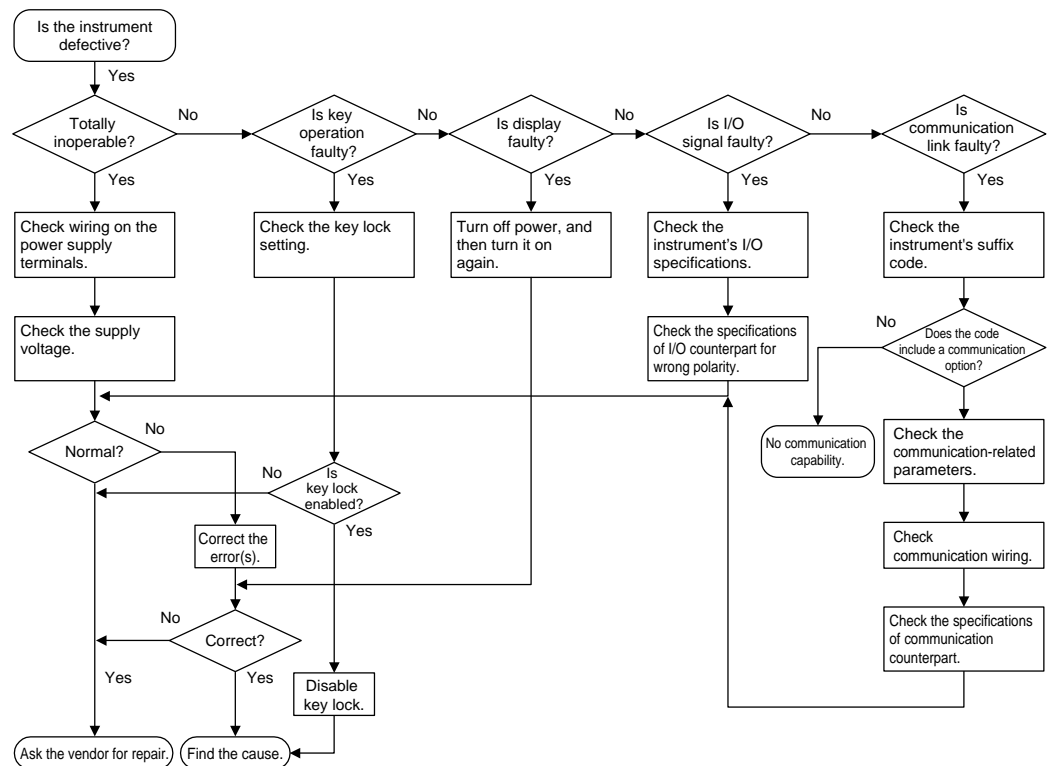

IMPORTANT

Take note of the parameter settings when asking the vendor for repair.

Errors at Power On

The following table shows errors that may be detected by the fault diagnosis function when the power is turned on.

Display position	Error indication	Description of error	PV	Control output	Alarm output	Retransmission output	Communication	Remedy
PV-indicating LED	E000	Faulty RAM	None	0% or less or OFF	OFF	0% or less	Stopped	Faulty Contact us for repair.
	E001	Faulty ROM	Undefined		Undefined	Undefined		
	E002	System data error	Undefined		Undefined	Undefined		
LCD	PV decimal point blinks.	Faulty calibration value	Normal action (out of accuracy)	Normal action (out of accuracy)	Normal action (out of accuracy)	Normal action (out of accuracy)	Normal operation	Check and set the initialized parameter.
	Error code (See description below.)	Parameter error	Normal action	0% or less or OFF	Normal action	Normal action		

An error code is displayed in the event of an error, according to its type. An error code is a two-digit figure in which a combination of 6 bits of on and off is converted into a decimal number. The following shows the relationship between each bit and parameter to be checked for abnormality.

Bit No.	6	5	4	3	2	1	0
Parameter to be checked	Operation mode/output	Operating parameters	Setup parameters	Range data	UT mode	Custom computing data	Calibration data

For example, if an error occurs with the operating parameter and calibration data, the error code will be as follows:

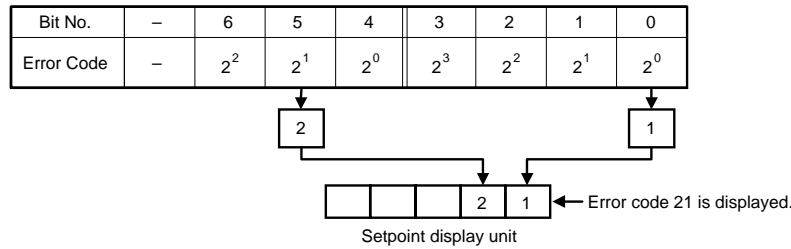

Possible Errors during Operation

The following shows possible errors occurring during operations.

Display position (Note)	Error indication	Description of error	PV	Control output	Alarm output	Retransmission output	Communication	Remedy
3	Displays "RJC" and PV alternately	RJC error	Measured with RJC=OFF	Normal action				Faulty Contact us for repair.
	E300	ADC error	105%					
	B.OUT	PV burnout error	Dependent on the BSL parameter Up-scale: 105% Down-scale: -5%	In AUTO: Preset value output In MAN: Normal action				
	OVER or -OVER	Excessive PV Out of -5 to 105%	-5% or 105%	Normal action				
2	Setpoint display	Feedback resistor breakdown	Normal action	Stopped		Stopped		Check the feedback resistor.
	Left end of SP display unit blinks.	Faulty communication line		Normal action		Normal action		
1	Decimal point at right end lights.	Runaway (due to defective power or noise)	Undefined					Faulty if power off does not reset start the unit. Contact us for repair.
-	All indications off	Power off	None					Check for abnormal power.

Note: 1: PV-indicating LED display
2: LCD
3: Display showing the PV of the loop on which the error has been caused

Remedies if Power Failure Occurs during Operations

The operation status and remedies after a power failure differ with the length of power failure time:

- Instantaneous power failure of 20 ms or less
A power failure is not detected. Normal operation continues.
- Power failure of about 2 seconds or less
The following show effects caused in "settings" and "operation status."

Alarm action	Continues. Alarm with standby function will enter standby status.
Setting parameter	Set contents of each parameter are retained.
Auto-tuning	Cancelled.
Control action	Action before power failure continues.

- Power failure of more than about 2 seconds
The following show effects caused in "settings" and "operation status."

Alarm action	Continues. Alarm with standby function will enter standby status.
Setting parameter	Set contents of each parameter are retained.
Auto-tuning	Cancelled.
Control action	Differs with setting of setup parameter "R.MD" (restart mode). R.MD setting Control action after recovery from power failure CONT Continues action before power failure. (Factory-set default) For position-proportional type, when V.MOD = Valve position estimating type, starts action from 0%. MAN Outputs preset output value (PO) as control output and continues action set before power failure in MAN mode. For position-proportional type, when V.MOD = Valve position feedback type, starts action from feedback input condition at recovery from power failure. When V.MOD = Valve position estimating type, starts action from 0%. For heating/cooling control, starts action from heating-side output value and cooling-side output value of 50% of control computation output. AUTO Outputs preset output value (PO) as control output and continues action set before power failure in AUTO mode. For position-proportional type, when V.MOD = Valve position feedback type, starts action from feedback input condition at recovery from power failure. When V.MOD = Valve position estimating type, starts action from 0%. For heating/cooling control, starts action from heating-side output value and cooling-side output value of 50% of control computation output.

Troubleshooting When the Controller Fails to Operate Correctly

If your control tasks are not successful, check the preset parameters and controller wiring before concluding the controller to be defective. The following show some examples of troubleshooting you should refer to in order to avoid the possibility of other problems.

- The controller does not show the correct measured input (PV).

The UT750 controllers have a universal input. The type of PV input can be set/changed using the parameter "INI". At this point, the controller must be wired correctly according to the selected type of PV input. Check the wiring first if the controller fails to show the correct PV value. To do this, refer to "Initial Settings User's Manual". With the parameters "RH1", "RL1", "SDP1", "SH1" and "SL1", it is possible to scale the input signal and change its number of decimal places. Also check that these parameters are configured correctly.

- The controller does not provide any control output or the control output does not change at all.

The UT750 controllers have a universal output. The type of control output can be set/changed using the parameter "OT1". At this point, the controller must be wired correctly according to the selected type of control output. Check the wiring first if the controller provides no control output. To do this, refer to "Terminal Wiring Diagrams," in "Installation User's Manual".

With the parameters "OH" and "OL", it is possible to set/change the high and low limits of control output. The control output may not change at all, however, because of restrictions on these parameters. Also check the restrictions on these parameters.

- The control output can only be changed when the controller is in the MAN mode. If the MAN1 lamp is off (i.e., the controller is in the AUTO mode), you cannot change the control output using key operation.

- The control output does not change soon after the target setpoint SP has been changed.

If this happens, check the setpoint of the parameter "MOD". In cases where fixed-point control is selected as the PID control mode (MOD = 1), tracking based on the I-term works to prevent the control output from changing suddenly even if the target setpoint SP is varied. The control output therefore may appear to be working incorrectly at first; however it gradually adapts itself to the new target setpoint.



This manual contains a parameter map as a guideline for setting parameters.

If you are unsure of the key operation sequence, press the **[DISP]** key (no more than four times). This displays a screen at power on (i.e., operating display).

Determine PV input type first. Settings herein are described in "2. Setting PV Input Type (Setting First at Power-on)", in **Initial Settings User's Manual**.

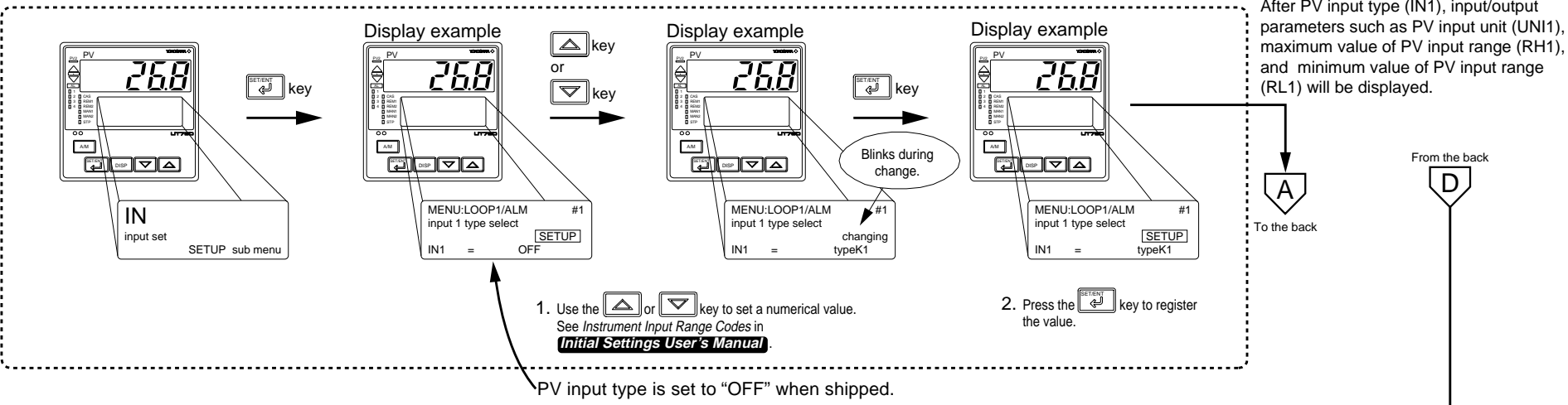

- Basic Key Operation Sequence**
- Setting display can be switched (moved) using the **[DISP]** key.
 - A numerical value is changed by:
 - Using the **[UP]** or **[DN]** key to change a displayed value ("changing" blinking) and
 - Pressing the **[ENT]** key to register it.
 - Pressing the **[DISP]** key on an operating display (for more than 3 seconds) brings you to the operating parameter setting display.
 - Pressing the **[DISP]** key on the operating parameter setting display (for more than 3 seconds) returns you to the operating display. To change from the operating parameter setting display to the operating parameter menu display, press the **[ENT]** key.
 - Pressing the **[DISP]** key on the setup parameter setting display (for more than 3 seconds) returns you to the operating display. To change from the setup parameter setting display to the setup parameter menu display, press the **[ENT]** key.

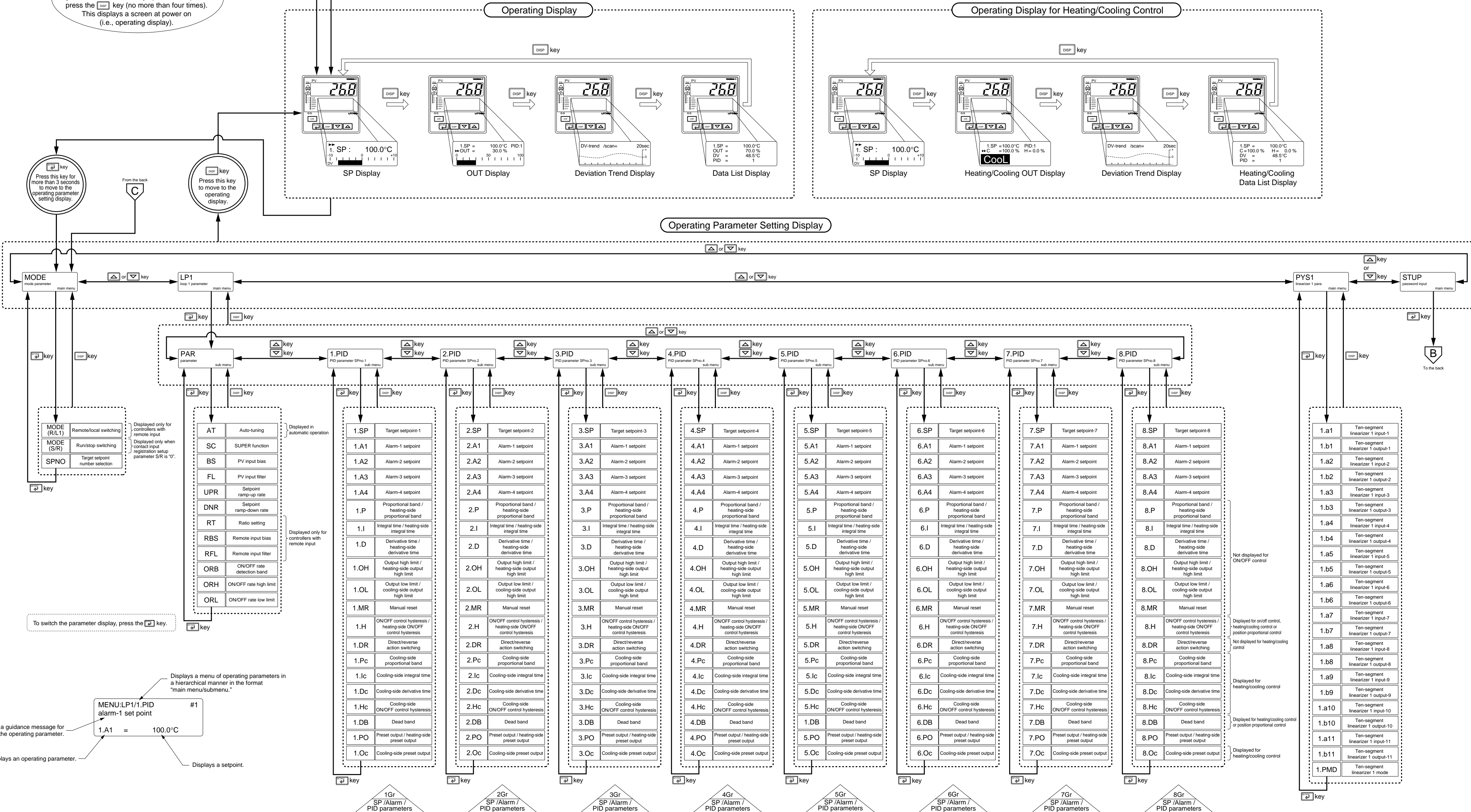

Displays a guidance message for the operating parameter.
 Displays an operating parameter.
 Displays a setpoint.



NOTE

Changing the registered value of a setup parameter may cause the registered value of an operating parameter to be initialized automatically. Thus, when you have changed a setup parameter, always check that the registered value of the operating parameter is appropriate. If it is initialized to default, reset it to the required value.

Setup Parameter Setting Display

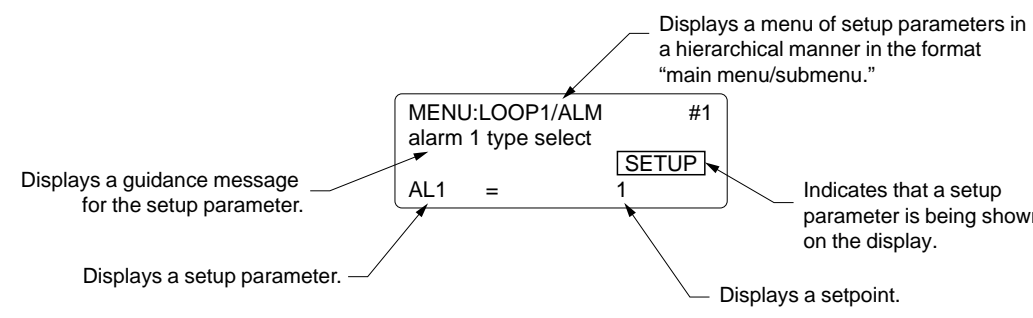
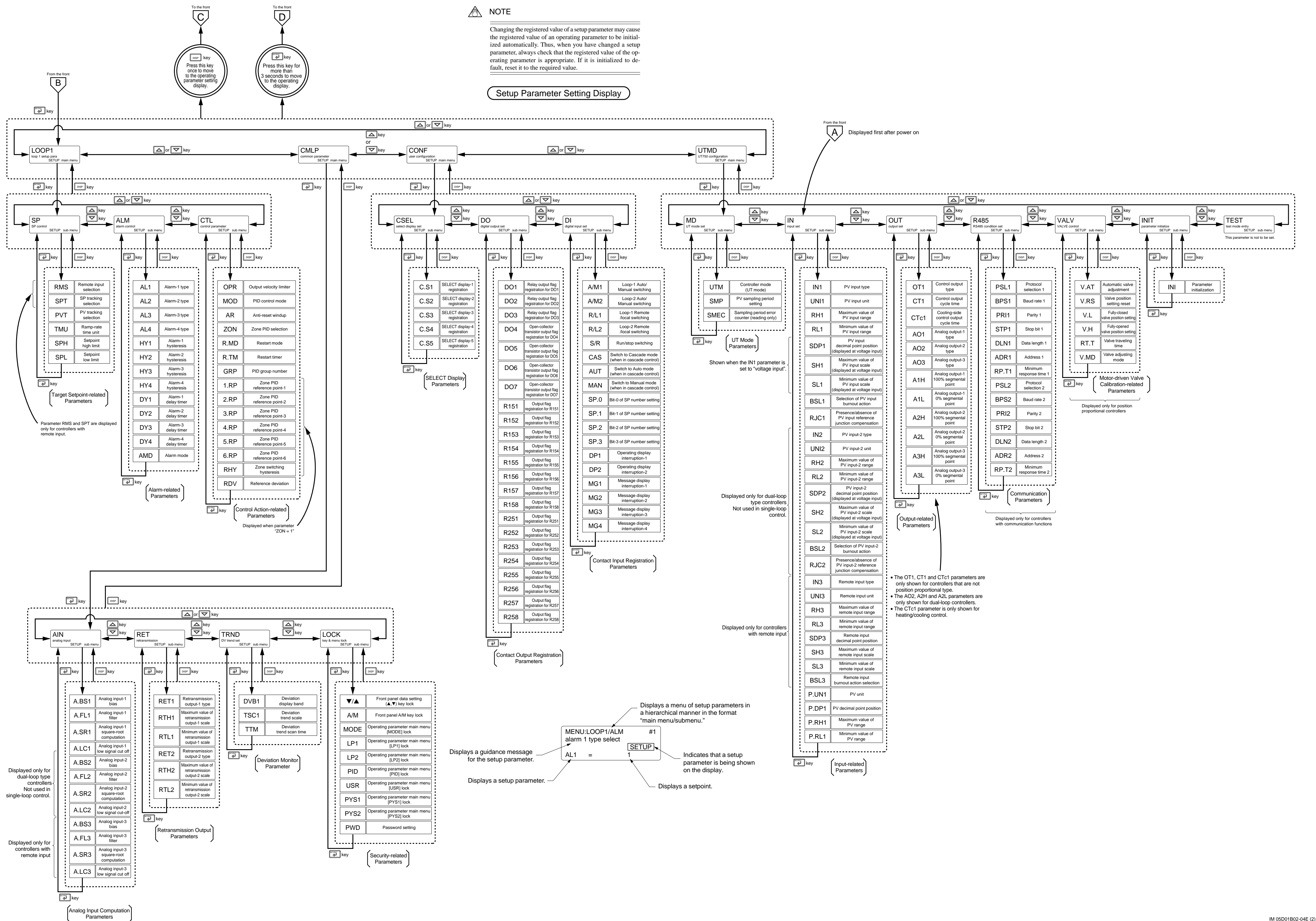

This manual describes the functions of parameters briefly. In addition, each parameter table has a "User Setting" column, where you can record your setpoints when setting them in the controller.

* Parameters relating to PV or setpoints should all be set in real numbers. For example, use temperature values to define target setpoints and alarm setpoints for temperature input.

Operating Parameters

Operation Mode Parameters

Located in: Main menu = MODE

Parameter Symbol	Name of Parameter	Setting Range and Description	Initial Value	User Setting	Target Item in CD-ROM
MODE (R/L1)	Remote/Local switching	Set to "Local" when carrying out control using the target setpoints of the controller or to "Remote" when using target setpoints acquired via a remote input signal or communication. Use the setup parameter RMS. "Remote Input Selection," to determine whether the target setpoints should be acquired via the remote input signal or communication. REMOTE: Remote mode LOCAL: Local mode	LOCAL		—
MODE (S/R)	Run/Stop switching	Outputs the predetermined (preset) fixed value when the controller stops. A preset output value can be defined for each target setpoint using the operating parameter "PO". STOP: Stops operation. RUN: Starts operation.	RUN		—
SPNO	Target setpoint number selection	1: Selects target setpoint-1 (1.SP). 2: Selects target setpoint-2 (2.SP). 3: Selects target setpoint-3 (3.SP). 4: Selects target setpoint-4 (4.SP). Likewise, options 5 to 8 select target setpoints 5 (5.SP) to 8 (8.SP).	1		—

Operation-related Parameters

Located in: Main menu = LP1 ; Submenu = PAR

Parameter Symbol	Name of Parameter	Setting Range and Description	Initial Value	User Setting	Target Item in CD-ROM
AT	Auto-tuning	OFF: No auto-tuning 1: Auto-tuning for 1.SP 2: Auto-tuning for 2.SP 3: Auto-tuning for 3.SP 4: Auto-tuning for 4.SP 5 to 8: Perform auto-tuning on a group basis in the same way as 1 to 4 9: Performs auto-tuning to all groups 1 to 8.	OFF		—
SC	"SUPER" function	OFF: Disable 1: Overshoot suppressing function Suppresses overshoots generated by abrupt changes in the target setpoint or by disturbances. 2: Hunting suppressing function (Stable mode) Stabilizes the state of control when the load varies greatly, or the target setpoint is changed. Enables to transfer the wider characteristic changes compared with Response mode. 3: Hunting suppressing function (Response mode) Enables quick follow-up and short converging time of PV for the changed target setpoint. Note: Use "SUPER" function (SC) 2 or 3 in PID control or PI control. "SUPER" function 2 or 3 is not available in the following control: 1) ON/OFF control 2) P control (control for proportional band only) 3) PID control (control for proportional band and derivative item only) 4) Heating/cooling control Do not use hunting suppressing function when control process with response such as flow or pressure control.	OFF		Ref.2.1(5) Ref.2.1(6)
BS	PV input bias	-100.0% to 100.0% of PV input range span Used to correct the PV input value.	0.0% of PV input range span		Ref.1.1(1)
FL	PV input filter	OFF: 1 to 120 sec Used when the PV input value fluctuates.	OFF		Ref.1.1(1)
UPR	Setpoint ramp-up rate	OFF 0.0% + 1 digit of PV input range span to 100.0% of PV input range span Set ramp-up-rate or ramp-down-rate per hour or minute. Sets unit in ramp-rate-time unit (TMU).	OFF		Ref.4.1(4)
DNR	Setpoint ramp-down rate	Used to prevent the target setpoint from changing suddenly. The ramp setting function works when: 1. the target setpoint is changed (e.g., "1.SP" is changed from 100°C to 150°C); 2. the target setpoint number (SPNO) is changed (e.g., the parameter is changed from 1.SP to 2.SP); 3. the power is turned on or has recovered from a failure; or 4. the operating mode is changed from Manual to Auto.	OFF		Ref.4.1(4)
RT	Ratio setting	0.001 to 9.999 Target setpoint = Remote input × Ratio setting + Remote bias	1.000		Ref.1.2(3)
RBS	Remote input bias	-100.0 to 100.0% of PV input range span Used to correct the remote input value.	0.0% of PV input range span		Ref.1.2(3)
RFL	Remote input filter	OFF: 1 to 120 sec Used when the remote input value fluctuates.	OFF		Ref.3.3(4)
ORB	ON/OFF rate detection band	0.0 to 100.0% of PV input range span	1.0% of PV input range span		Ref.3.3(4)
ORH	ON/OFF rate high limit	ORL + 1 digit to 105.0%	100.0%		Ref.3.3(4)
ORL	ON/OFF rate low limit	-5.0% to ORH - 1 digit	0.0%		Ref.3.3(4)

Setpoint-, Alarm- and PID-related Parameters

Located in: Main menu = LP1 ; Submenu = 1.PID

The table below lists the Target Setpoint-1 (1.SP) operating parameter and parameters that apply to the 1.SP parameter.

Parameter Symbol	Name of Parameter	Setting Range and Description	Initial Value	User Setting	Target Item in CD-ROM
1.SP	Target setpoint-1	0.0 to 100.0% of PV input range However, between target setpoint limiter lower limit (SPL) and upper limit (SPH).	0.0% of PV input range		Ref.4.1(1)
1.A1	Alarm-1 setpoint	PV alarm / SP alarm: -100.0 to 100.0% of PV input range Deviation alarm: -100.0 to 100.0% of PV input range span Output alarm: -5.0 to 105.0% Timer alarm (for alarm-1 only): 0.0 to 99.99 (hour, min) or (min, sec)	PV high limit/SP high limit alarm: 100.0% of PV input range Other PV/SP low limit alarm: 0.0% of PV input range		Ref.4.1(1)
1.A2	Alarm-2 setpoint	Output alarm: -5.0 to 105.0% Timer alarm (for alarm-2 only): 0.0 to 99.99 (hour, min) or (min, sec)	PV high limit alarm: 100.0% Output low limit alarm: 0.0%		Ref.4.1(1)
1.A3	Alarm-3 setpoint	Output alarm: -5.0 to 105.0% Timer alarm (for alarm-3 only): 0.0 to 99.99 (hour, min) or (min, sec)	PV high limit alarm: 100.0% Output low limit alarm: 0.0%		Ref.4.1(1)
1.A4	Alarm-4 setpoint	Output alarm: -5.0 to 105.0% Timer alarm (for alarm-4 only): 0.0 to 99.99 (hour, min) or (min, sec)	PV high limit alarm: 100.0% Output low limit alarm: 0.0%		Ref.4.1(1)
1.P	Proportional band/Heating-side proportional band (in heating/cooling control)	0.1 to 999.9% In heating/cooling control: 0.0 to 999.9% (heating-side on/off control applies when 0.0)	5.0%		Ref.4.1(1)
1.I	Integral time Heating-side integral time (in heating/cooling control)	OFF, 1 to 6000 sec.	240 seconds		Ref.4.1(1)

* The "User Setting" column in the table below is provided for the customer to record setpoints.

* The "Target Item in CD-ROM" column in the table below provides references from User's Manual (Reference) (CD-ROM Version) which describes items in more detail and items that are not contained in this manual.

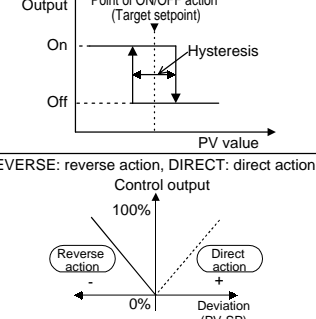
Parameter Symbol	Name of Parameter	Setting Range and Description	Initial Value	User Setting	Target Item in CD-ROM
1.D	Derivative time Heating-side derivative time (in heating/cooling control)	OFF, 1 to 6000 sec.	60 seconds		Ref.4.1(1)
1.OH	Output high limit Heating-side output high limit (in heating/cooling control)	-5.0 to 105.0% Heating-side limiter in heating/cooling control: 0.0 to 105.0% (LOL < 1.OH)	100% Heating/cooling control: 100.0%		Ref.2.1(3)
1.OL	Output low limit Cooling-side output high limit (in heating/cooling control)	-5.0 to 105.0% Cooling-side limiter in heating/cooling control: 0.0 to 105.0% (LOL < 1.OH) SD (shutdown): Set in manual operation in 4-20 mA control output.	0.0% Heating/cooling control: 100.0%		Ref.4.1(1)
1.MR	Manual reset	-5.0 to 105.0% (enabled when integral time "1.I" is OFF) The manual reset value equals the output value when PV = SP is true. For example, if the manual reset value is 50%, the output value is 50% when PV = SP becomes true.	50.0%		Ref.1.1(2)
1.H	ON/OFF control hysteresis Heating-side ON/OFF control hysteresis	In ON/OFF control: 0.0 to 100.0% of PV input range span Position proportional PID control or heating/cooling control: 0.0 to 100.0% Hysteresis can be set in the target setpoint when the controller is performing ON (Target setpoint) control. 	ON/OFF control: 0.5% of PV input range span Position proportional PID control and heating/cooling control: 0.5%		Ref.4.1(1)
1.DR	Direct/reverse action switching	REVERSE: reverse action, DIRECT: direct action	REVERSE		Ref.2.1(1) Ref.4.1(1)
1.Pc	Cooling-side proportional band	0.0 to 999.9% (Cooling-side ON/OFF control applies when 0.0)	5.0%		Ref.4.1(1)
1.Ic	Cooling-side integral time	OFF, 1 to 6000 sec.	240 seconds		Ref.4.1(1)
1.Dc	Cooling-side derivative time	OFF, 1 to 6000 sec.	60 seconds		Ref.4.1(1)
1.Hc	Cooling-side ON/OFF control hysteresis	0.0 to 100.0%	0.5%		Ref.4.1(1)
1.DB	Dead band	In heating/cooling control: -100.0 to 50.0% In position proportional PID control: 1.0 to 10.0% * In heating/cooling control: When setting any positive value, there is region where none of the heating- and cooling-side output is presented; when setting any negative value, there is a region where both of the heating- and cooling-side outputs are presented. When setting a value of zero, either the heating- and cooling-side output is provided. * In position proportional control: Set the range so none of the outputs turn on.	3.0%		Ref.4.1(1)
1.PO	Preset output/Heating-side preset output (in heating/cooling control)	-5.0 to 105.0% In heating/cooling control: Heating side 0.0 to 105.0% In Stop state, fixed control output can be generated.	0.0%		Ref.2.1(8)
1.Oc	Cooling-side preset output	0.0 to 105.0% In Stop state, cooling-side fixed control output can be generated.	0.0%		Ref.4.1(1)

If you are using two or more groups of setpoint, alarm and PID parameters, use the following table to record their values.

Parameter	n=2	n=3	n=4	n=5	n=6	n=7	n=8
n.SP							
n.A1							
n.A2							
n.A3							
n.A4							
n.P							
n.I							
n.D							
n.OH							
n.OL							
n.MR							
n.H							
n.DR							
n.Pc							
n.Ic							
n.Hc							
n.DB							
n.PO							
n.Oc							

Ten-segment Linearizer 1 Parameters

Located in: Main menu = PYS1

Ten-segment linearizer biasing (factory-set default) Ten-segment linearizer approximation

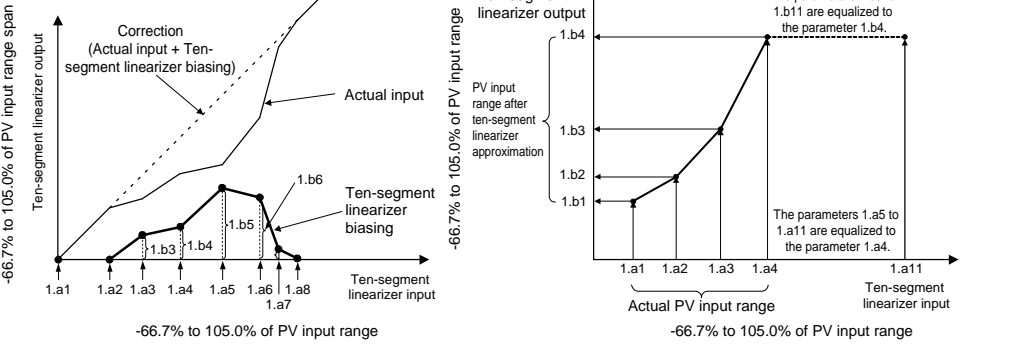

Parameter Symbol	Name of Parameter	Setting Range and Description	Initial Value	User Setting	Target Item in CD-ROM
1.a1	Ten-segment linearizer 1 input-1	-66.7% to 105.0% of PV input range	0.0% of PV input range		Ref.1.1(2)
1.b1	Ten-segment linearizer 1 output-1	-66.7% to 105.0% of PV input range span -66.7% to 105.0% of PV input range when in ten-segment linearizer approximation	0.0% of PV input range span 0.0% of PV input range when in ten-segment linearizer approximation		Ref.1.1(2)
1.a2	Ten-segment linearizer 1 input-2	-66.7% to 105.0% of PV input range	0.0% of PV input range		Ref.1.1(2)
1.b2	Ten-segment linearizer 1 output-2	-66.7% to 105.0% of PV input range span -66.7% to 105.0% of PV input range when in ten-segment linearizer approximation	0.0% of PV input range span 0.0% of PV input range when in ten-segment linearizer approximation		Ref.1.1(2)
1.a3	Ten-segment linearizer 1 input-3	-66.7% to 105.0% of PV input range	0.0% of PV input range		Ref.1.1(2)
1.b3	Ten-segment linearizer 1 output-3	-66.7% to 105.0% of PV input range span -66.7% to 105.0% of PV input range when in ten-segment linearizer approximation	0.0% of PV input range span 0.0% of PV input range when in ten-segment linearizer approximation		Ref.1.1(2)
1.a4	Ten-segment linearizer 1 input-4	-66.7% to 105.0% of PV input range	0.0% of PV input range		Ref.1.1(2)
1.b4	Ten-segment linearizer 1 output-4	-66.7% to 105.0% of PV input range span -66.7% to 105.0% of PV input range when in ten-segment linearizer approximation	0.0% of PV input range span 0.0% of PV input range when in ten-segment linearizer approximation		Ref.1.1(2)

1.a5	Ten-segment linearizer 1 input-5	-66.7% to 105.0% of PV input range	0.0% of PV input range		Ref.1.1(2)
1.b5	Ten-segment linearizer 1 output-5	-66.7% to 105.0% of PV input range span -66.7% to 105.0% of PV input range when in ten-segment linearizer approximation	0.0% of PV input range span 0.0% of PV input range when in ten-segment linearizer approximation		Ref.1.1(2)
1.a6	Ten-segment linearizer 1 input-6	-66.7% to 105.0% of PV input range	0.0% of PV input range		Ref.1.1(2)
1.b6	Ten-segment linearizer 1 output-6	-66.7% to 105.0% of PV input range span -66.7% to 105.0% of PV input range when in ten-segment linearizer approximation	0.0% of PV input range span 0.0% of PV input range when in ten-segment linearizer approximation		Ref.1.1(2)
1.a7	Ten-segment linearizer 1 input-7	-66.7% to 105.0% of PV input range	0.0% of PV input range		Ref.1.1(2)
1.b7	Ten-segment linearizer 1 output-7	-66.7% to 105.0% of PV input range span -66.7% to 105.0% of PV input range when in ten-segment linearizer approximation	0.0% of PV input range span 0.0% of PV input range when in ten-segment linearizer approximation		Ref.1.1(2)
1.a8	Ten-segment linearizer 1 input-8	-66.7% to 105.0% of PV input range	0.0% of PV input range		Ref.1.1(2)
1.b8	Ten-segment linearizer 1 output-8	-66.7% to 105.0% of PV input range span -66.7% to 105.0% of PV input range when in ten-segment linearizer approximation	0.0% of PV input range span 0.0% of PV input range when in ten-segment linearizer approximation		Ref.1.1(2)
1.a9	Ten-segment linearizer 1 input-9	-66.7% to 105.0% of PV input range	0.0% of PV input range		Ref.1.1(2)
1.b9	Ten-segment linearizer 1 output-9	-66.7% to 105.0% of PV input range span -66.7% to 105.0% of PV input range when in ten-segment linearizer approximation	0.0% of PV input range span 0.0% of PV input range when in ten-segment linearizer approximation		Ref.1.1(2)
1.a10	Ten-segment linearizer 1 input-10	-66.7% to 105.0% of PV input range	0.0% of PV input range		Ref.1.1(2)
1.b10	Ten-segment linearizer 1 output-10	-66.7% to 105.0% of PV input range span -66.7% to 105.0% of PV input range when in ten-segment linearizer approximation	0.0% of PV input range span 0.0% of PV input range when in ten-segment linearizer approximation		Ref.1.1(2)
1.a11	Ten-segment linearizer 1 input-11	-66.7% to 105.0% of PV input range	0.0% of PV input range		Ref.1.1(2)
1.b11	Ten-segment linearizer 1 output-11	-66.7% to 105.0% of PV input range span -66.7% to 105.0% of PV input range when in ten-segment linearizer approximation	0.0% of PV input range span 0.0% of PV input range when in ten-segment linearizer approximation		Ref.1.1(2)
1.PMD	Ten-segment linearizer 1 mode	0: Ten-segment linearizer biasing 1: Ten-segment linearizer approximation	0		Ref.1.1(2)

Setup Parameters

Target Setpoint-related Parameters

Located in: Main menu = LOOP1 ; Submenu = SP

Parameter Symbol	Name of Parameter	Setting Range and Description	Initial Value	User Setting	Target Item in CD-ROM
RMS	Remote input selection	RSP: Uses the value set remotely via remote input (terminals). COM: Uses the value set remotely via communication.	RSP		Ref.1.2(1)
SPT	SP tracking selection	OFF, ON Tracking is performed when the mode changes from Remote to Local (The local setpoint keeps track of the remote setpoint.)	ON		Ref.1.2(4)
PVT	PV tracking selection	Causes the setpoint to keep track of the PV value so the setpoint automatically reverts to its original value at a preset rate of change. The Setpoint Ramp-up rate (UPR) and Setpoint Ramp-down rate (DNR) parameters are used in combination. - Operating conditions - 1: Manual operation → Automatic operation; 2: Stop → Start of automatic operation; 3: Power-on; 4: Change SP number; 5: Change SP value OFF: Disable ON: Enable	OFF		Ref.1.1(7)
TMU	Ramp-rate time unit setting	Time unit of setpoint ramp-up rate (UPR) and setpoint ramp-down rate (DNR) HOUR: Denotes "per hour." MIN: Denotes "per minute."	HOUR		Ref.4.1(4)
SPH	Target setpoint limiter upper limit	0.0% to 100.0% of PV input range. Note that SPL < SPH	100.0% of PV input range		—
SPL	Target setpoint limiter lower limit	Places limits on the ranges within which the target setpoints (1.SP to 8.SP) are changed.	0.0% of PV input range		—

Alarm-related Parameters

Located in: Main menu = LOOP1 ; Submenu = ALM

Parameter Symbol	Name of Parameter	Setting Range and Description	Initial Value	User Setting	Target Item in CD-ROM
AL1	Alarm-1 type	OFF: 1 to 31 (same as below) Common to all target setpoints.	1		Ref.3.3(3) Ref.3.3(4)
AL2	Alarm-2 type	OFF: 1 to 20, 25 to 31 1: PV high limit (energized, no stand-by action) 2: PV low limit (energized, no stand-by action) 3: Deviation high limit (energized, no stand-by action) 4: Deviation low limit (energized, no stand-by action) 5: Deviation high limit (de-energized, no stand-by action) 6: Deviation low limit (de-energized, no stand-by action) For other alarm types, see Initial Settings User's Manual Common to all target setpoints.	2		Ref.3.3(4)
AL3	Alarm-3 type	OFF: 1 to 20, 25 to 31 1: PV high limit (energized, no stand-by action) 2: PV low limit (energized, no stand-by action) 3: Deviation high limit (energized, no stand-by action) 4: Deviation low limit (energized, no stand-by action) 5: Deviation high limit (de-energized, no stand-by action) 6: Deviation low limit (de-energized, no stand-by action) For other alarm types, see Initial Settings User's Manual Common to all target setpoints.	1		Ref.3.3(4)
AL4	Alarm-4 type	OFF: 1 to 20, 25 to 31 1: PV high limit (energized, no stand-by action) 2: PV low limit (energized, no stand-by action) 3: Deviation high limit (energized, no stand-by action) 4: Deviation low limit (energized, no stand-by action) 5: Deviation high limit (de-energized, no stand-by action) 6: Deviation low limit (de-energized, no stand-by action) For other alarm types, see Initial Settings User's Manual Common to all target setpoints.	2		Ref.3.3(4)
HY1	Alarm-1 hysteresis	0.0 to 100.0% of PV input range span Output alarm: 0.0 to 100.0%	0.5% of PV input range span		Ref.3.3(2)
HY2	Alarm-2 hysteresis	Allows margins to be set for an alarm setpoint. With the hysteresis settings, it is possible to prevent relays from chattering. Hysteresis for PV high limit alarm Output alarm: 0.5%	0.5%		Ref.3.3(2)
HY3	Alarm-3 hysteresis	Output Point of ON/OFF action (Alarm setpoint) On Off Hysteresis			Ref.3.3(2)
HY4	Alarm-4 hysteresis	Output Point of ON/OFF action (Alarm setpoint) On Off Hysteresis			Ref.3.3(2)
DY1	Alarm-1 delay timer	0.00 to 99.99 (min, sec.) (enabled when alarm-1 type "AL1" is 1 to 20 or 28 to 31) An alarm is output when the delay timer expires after the alarm setpoint is reached.	0.00		Ref.3.3(1)
DY2	Alarm-2 delay timer	0.00 to 99.99 (min, sec.) (enabled when alarm-2 type "AL2" is 1 to 20 or 28 to 31)			Ref.3.3(1)
DY3	Alarm-3 delay timer	0.00 to 99.99 (min, sec.) (enabled when alarm-3 type "AL3" is 1 to 20 or 28 to 31)			Ref.3.3(1)
DY4	Alarm-4 delay timer	0.00 to 99.99 (min, sec.) (enabled when alarm-4 type "AL4" is 1 to 20 or 28 to 31)			Ref.3.3(1)
AMD	Alarm mode	Allows the alarm function to be enabled or disabled according to the operating condition. 0: Always active 1: Not active when in Stop mode 2: Not active when in Stop mode or manual operation	0		Ref.3.3(1)

Control Action-related Parameters

Located in: Main menu = LOOP1 ; Submenu = CTL

Parameter Symbol	Name of Parameter	Setting Range and Description	Initial Value	User Setting	Target Item in CD-ROM
OPR	Output velocity limiter	OFF (0) 0.1 to 100.0%/sec can limit control output velocity	OFF		—
MOD	PID control mode	0: Standard PID control (with output bump at SP change) 1: Fixed-point control (without output bump at SP change) Choose "Fixed-point Control" when controlling pressure or flow rate.	0		Ref.2.1(2)
AR	Anti-reset windup (Excess integration prevention)	AUTO (0): 50.0 to 200.0% The larger Setting, the sooner PID computation (integral computation) stops. Used when the control output travels up to 100% or down to 0			

● Deviation Monitor Parameters

Located in: Main menu = CMLP ; Submenu = TRND

Parameter Symbol	Name of Parameter	Setting Range and Description	Initial Value	User Setting	Target Item in CD-ROM
DVB1	Deviation display band	0.0 to 100.0% of PV input range span Permits a change in the span of deviation shown on the front-panel deviation monitor.	1.0% of PV input range span		Ref.6.1(3)
TSC1	Deviation trend scale	Allows the deviation axis on the Deviation Trend operating display to be re-scaled.	5.0% of PV input range span		
TTM	Deviation trend scan time	0 to 600 sec. Allows the time axis on the Deviation Trend operating display to be re-scaled.	5 sec.		Ref.6.1(2)

● Security-related Parameters

Located in: Main menu = CMLP ; Submenu = LOCK

Parameter Symbol	Name of Parameter	Setting Range and Description	Initial Value	User Setting	Target Item in CD-ROM
▼/▲	Front panel data setting (▲, ▼) key lock	OFF: Unlock ON: Lock	OFF		
A/M	Front panel A/M key lock	OFF: Unlock ON: Lock	OFF		
MODE	Operating parameter main menu [MODE] lock	OFF: Unlock ON: Lock	OFF		
LP1	Operating parameter main menu [LP1] lock	OFF: Unlock ON: Lock	OFF		Ref.7.1(2)
LP2	Although not used in single-loop control, it is shown on the display.				
PID	Operating parameter main menu [PID] lock	OFF: Unlock ON: Lock	OFF		
USR	Although not used in single-loop control, it is shown on the display.				
PYS1	Operating parameter main menu [PYS1] lock	OFF: Unlock ON: Lock	OFF		
PYS2	Although not used in single-loop control, it is shown on the display.				
PWD	Password setting	0: Password not set 1 to 30000	0		Ref.7.1(1)

● SELECT Display Parameters

Located in: Main menu = CONF ; Submenu = CSEL

Parameter Symbol	Name of Parameter	Setting Range and Description	Initial Value	User Setting	Target Item in CD-ROM
C.S1	SELECT display-1 registration	OFF, 201 to 1023 Select the desired parameter from among the operating and setup parameters, then register the number (ID register No.) accompanying that parameter.	OFF		
C.S2	SELECT display-2 registration	Same as C.S1			
C.S3	SELECT display-3 registration	Same as C.S1			
C.S4	SELECT display-4 registration	Same as C.S1			
C.S5	SELECT display-5 registration	Same as C.S1			

● Contact Output Registration Parameters

Located in: Main menu = CONF ; Submenu = DO

Parameter Symbol	Name of Parameter	Setting Range and Description	Initial Value	User Setting	Target Item in CD-ROM
DO1	Relay output flag registration for DO1	The following setpoints are registration numbers for single-loop control only.	5689		
DO2	Relay output flag registration for DO2	5688: Alarm-1 output 5690: Alarm-2 output	5690		
DO3	Relay output flag registration for DO3	5691: Alarm-3 output 5693: Alarm-4 output	1607		
DO4	Open-collector transistor output flag registration for DO4	The following setpoints are only available for heating/cooling control.	1609		Ref.3.2(1)
DO5	Open-collector transistor output flag registration for DO5	1607: Cooling-side output 1609: Cooling-side output	5691		
DO6	Open-collector transistor output flag registration for DO6	Both the setpoints 1607 and 1609 provide the same cooling-side output value.	5693		
DO7	Open-collector transistor output flag registration for DO7		0		

Parameters R151 to R258 are shown only for a controller with a communication option. See the CD-ROM edition of the user's manual for details on how to use these parameters.

● Contact Input Registration Parameters

Located in: Main menu = CONF ; Submenu = DI

Parameter Symbol	Name of Parameter	Setting Range and Description	Initial Value	User Setting	Target Item in CD-ROM
A/M1	Loop-1 Auto/Manual switching	These parameters determine which contact input to use to make selections/switches listed on the left.	5165		
A/M2	Loop-2 Auto/Manual switching	DI1: 5161 No function: 0	0		
R/L1	Loop-1 Remote/Local switching	DI3: 5163 DI4: 5164	5167		
R/L2	Loop-2 Remote/Local switching	DI5: 5165 DI6: 5166 DI7: 5167	0		
S/R	Run/Stop switching	The contact inputs are factory-set as shown below.	5166		
CAS	Switch to Cascade mode (when in cascade control)	Contact inputs 1 to 4 (DI1 to DI4): SP selection (see table below) Contact input 5 (DI5): Auto (ON)/Manual (OFF) switching Contact input 6 (DI6): Run (OFF)/Stop (ON) switching Contact input 7 (DI7): Remote (ON)/Local (OFF) switching	0		Ref.3.1(4)
AUTO	Switch to Auto mode (when in cascade control)		0		
MAN	Switch to Manual mode (when in cascade control)		0		
SP.0	Bit-0 of SP number setting	1.SP 2.SP 3.SP 4.SP 5.SP 6.SP 7.SP 8.SP	5161		
SP.1	Bit-1 of SP number setting	DI1 OFF ON ON OFF OFF ON OFF ON ON OFF	5162		
SP.2	Bit-2 of SP number setting	DI3 OFF OFF OFF ON ON ON ON ON OFF	5163		
SP.3	Bit-3 of SP number setting	DI4 OFF OFF OFF OFF OFF OFF OFF ON	5164		Ref.1.1(8)

Parameter Symbol	Name of Parameter	Setting Range and Description	Initial Value	User Setting	Target Item in CD-ROM
DP1	Operating display interruption-1		0		
DP2	Operating display interruption-2		0		
MG1	Message display interruption-1		0		Ref.3.1(4)
MG2	Message display interruption-2		0		
MG3	Message display interruption-3		0		
MG4	Message display interruption-4		0		

● UT Mode Parameters

Located in: Main menu = UTMD ; Submenu = MD

Parameter Symbol	Name of Parameter	Setting Range and Description	Initial Value	User Setting	Target Item in CD-ROM
UTM	Controller mode (UT mode)	1: Single-loop control For another controller mode, see User's Manual (Reference) (CD-ROM version).	1		
SMP	PV sampling period setting	50, 100, 200 and 500 ms The controller restarts if any change is made to the PV sampling period; this does not affect other parameter settings at all, however.	200 ms		Ref.1.1(4)
SMEC	Sampling period error counter (reading only)	0 to 30000	Shows 0 at power-on.		Ref.1.1(5)

● Input-related Parameters

Located in: Main menu = UTMD ; Submenu = IN

Parameter Symbol	Name of Parameter	Setting Range and Description	Initial Value	User Setting	Target Item in CD-ROM
IN1	PV input type (INPUT 1 terminals Terminals ①, ② and ③)	Specify the type of PV input as a range code. See "Instrument Input Range Codes" in the Initial Settings User's Manual .	OFF		
UNI1	PV input unit	Select the unit of PV input. %: Percent °F: Fahrenheit °C: Degree Celsius -: No unit	Depend on the PV input type		
RH1	Max. value of PV input range	Set the PV input range (RL1 < RH1). - For temperature input - Set the range of temperature that is actually controlled. - For voltage input - Set the range of a voltage signal that is applied. The scale across which the voltage signal is actually controlled should be set using the parameters Maximum Value of PV Input Scale (SH1) and Minimum Value of PV Input Scale (SL1).	Depend on the PV input type		
RL1	Min. value of PV input range	Same as RH1			
SDP1	PV input decimal point position (shown when in voltage-input mode)	Set the position of the decimal point of voltage-mode PV input. 0 to 4: 0: No decimal place, 1: One decimal place, 2 to 4: Two, three, four decimal places	Depend on the PV input type		
SH1	Max. value of PV input scale (shown when in voltage-input mode)	Set the read-out scale of voltage-mode PV input. -19999 to 30000, where SL1 < SH1, SH1 - SL1 ≤ 30000	Depend on the PV input type		
SL1	Min. value of PV input scale (shown when in voltage-input mode)	Same as SH1			
BSL1	Selection of PV input burnout action	Allows the PV input value to be determined as shown below in case of PV input burnout. +105% of PV input range if set to "Upward" -5.0% of PV input range if set to "Downward" OFF: Disable UP: Upscale DOWN: Downscale	Depend on the PV input type		
RJC1	Presence/absence of PV input reference junction compensation	Allows input compensation to be applied to thermocouple input. OFF: Absent ON: Present	ON		
IN2	Although not used in single-loop control, it is shown on the display.				
UNI2	Although not used in single-loop control, it is shown on the display.				
RH2	Although not used in single-loop control, it is shown on the display.				
RL2	Although not used in single-loop control, it is shown on the display.				
SDP2	Although not used in single-loop control, it is shown on the display.				
SH2	Although not used in single-loop control, it is shown on the display.				
SL2	Although not used in single-loop control, it is shown on the display.				
BSL2	Although not used in single-loop control, it is shown on the display.				
RJC2	Although not used in single-loop control, it is shown on the display.				
IN3	Remote input type (INPUT 3 terminals Terminals ④ and ⑤)	Specify the type of remote input as a range code. See "Instrument Input Range Codes" in the Initial Settings User's Manual .	1 to 5 V		
UNI3	Remote input unit	Select the unit of remote input. %: Percent °F: Fahrenheit °C: Degree Celsius -: No unit	%		
RH3	Maximum value of remote input range	Set the range of a voltage signal. (RL3 < RH3)	5.000		
RL3	Minimum value of remote input range	Same as RH3	1.000		Ref.1.2(1)
SDP3	Remote input decimal point position	Set the position of the decimal point for remote input. 0 to 4	Same as the position of PV input's decimal point		
SH3	Max. value of remote input scale	Set the remote input read-out scale. -19999 to 30000, where SL3 < SH3, SH3 - SL3 ≤ 30000 Under normal operation, set the values of these parameters as shown below. - When PV input is temperature - Maximum and minimum values of PV input range - When PV input is voltage - Maximum and minimum values of PV input scale	Maximum value of PV input scale		
SL3	Min. value of remote input scale	Same as SH3	Minimum value of PV input scale		
BSL3	Remote input burnout action selection	Allows the remote input value to be determined as shown below in case of remote input burnout. +105% of remote input scale if set to "Upscale" -5.0% of remote input scale if set to "Downscale" OFF: Disable UP: Upscale DOWN: Downscale	OFF		
P.UN1	PV unit	Set the unit of PV. %: Percent °F: Fahrenheit °C: Degree Celsius -: No unit	Same as the unit of PV input		
P.DP1	PV decimal point position	Under normal operation, set the same value as in the PV input Decimal Point Position (SDP1) parameter. To shift the decimal point for temperature input, use this parameter. For example, set as "PDP1 = 0" to change a temperature reading of one decimal place to that of no decimal places. This involves reconfiguring the PRH1 and PRL1 parameters. 0 to 4			Ref.1.1(8)
P.RH1	Maximum value of PV range	Under normal operation, keep the values of these parameters between the maximum and minimum values of the PV input range. -19999 to 30000	Maximum value of PV input range or scale		
P.RL1	Minimum value of PV range	Same as P.RH1	Minimum value of PV input range or scale		

● Output-related Parameters

Located in: Main menu = UTMD ; Submenu = OUT

Parameter Symbol	Name of Parameter	Setting Range and Description	Initial Value	User Setting	Target Item in CD-ROM
OT1	Control output type	0 Time proportional PID relay contact output (terminals ①-②-③) 1 Time proportional PID voltage pulse output (terminals ④-⑤) 2 Current output (terminals ⑥-⑦) 3 ON/OFF control relay contact output (terminals ①-②-③) 4 Heating-side relay output (terminals ①-②-③), cooling-side relay output (terminals ④-⑤) 5 Heating-side pulse output (terminals ⑥-⑦), cooling-side relay output (terminals ①-②) 6 Heating-side current output (terminals ④-⑤), cooling-side relay output (terminals ①-②-③), cooling-side transistor output (terminals ⑥-⑦) 7 Heating-side pulse output (terminals ①-②-③), cooling-side transistor output (terminals ④-⑤) 8 Heating-side pulse output (terminals ⑥-⑦), cooling-side transistor output (terminals ①-②) 9 Heating-side current output (terminals ⑥-⑦), cooling-side transistor output (terminals ④-⑤) 10 Heating-side relay output (terminals ①-②-③), cooling-side current output (terminals ④-⑤) 11 Heating-side pulse output (terminals ⑥-⑦), cooling-side current output (terminals ①-②) 12 Heating-side current output (terminals ⑥-⑦), cooling-side current output (terminals ④-⑤)	0		
CT1	Control output cycle time Heating-side control output cycle time in heating/cooling control	1 to 1000 seconds 	30 seconds		Ref.3.3(4)
CTc1	Cooling-side control output cycle time	1 to 1000 seconds	30 seconds		
AO1	Analog output-1 type (OUTPUT 1: Terminals ⑧ and ⑨)	Allows control output or retransmission output to be presented as one of the following current signals. 0: 4 to 20 mA 1: 0 to 20 mA 2: 2 to 4 mA 3: 2 to 0 mA	0		
AO2	Analog output-2 type (OUTPUT 2: Terminals ⑩ and ⑪)	Same as AO1	0		
AO3	Analog output-3 type (OUTPUT 3: Terminals ⑫ and ⑬)	Same as AO1	0		
A1H	Analog output-1 100% segmental point	Set the values of segmental points for the 0% and 100% output levels at which the values are presented via OUTPUT-1 (terminals ⑧ and ⑨). See "Performing Split Computations" below.	100.0 %		Ref.2.1(7)
A1L	Analog output-1 0% segmental point	-5.0% to 105.0%, where A1L < A1H	0.0 %		
A2H	Analog output-2 100% segmental point	Set the values of segmental points for the 0% and 100% output levels at which the values are presented via OUTPUT-2 (terminals ⑩ and ⑪). See "Performing Split Computations" below.	100.0 %		
A2L	Analog output-2 0% segmental point	-5.0% to 105.0%, where A2L < A2H	0.0 %		
A3H	Analog output-3 100% segmental point	Set the values of segmental points for the 0% and 100% output levels at which the values are presented via OUTPUT-3 (terminals ⑫ and ⑬). See "Performing Split Computations" below.	100.0 %		
A3L	Analog output-3 0% segmental point	-5.0% to 105.0%, where A3L < A3H	0.0 %		

■ Performing Split Computations

• V-mode Output

The following explains an example of letting "Analog OUTPUT-1 (terminals ⑧ and ⑨)" and "Analog OUTPUT-3 (terminals ⑫ and ⑬)" present the V-mode characteristics of split computations.
[1]Set the Control Output Type (OT1) parameter to "2".
This sets the control output to "current output."
[2]Set the Retransmission Output1 (RET1) parameter to "3".
This sets the retransmission output to "control output retransmission."
[3]Set the Analog Output-1 100% Segmental Point (A1H) parameter to "100%".
[4]Set the Analog Output-1 0% Segmental Point (A1L) parameter to "25%".
[5]Set the Analog Output-3 100% Segmental Point (A3H) parameter to "0%".
[6]Set the Analog Output-3 0% Segmental Point (A3L) parameter to "75%".

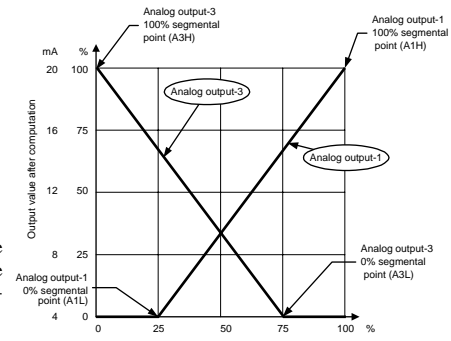

The figure on the right shows an example where both analog outputs-1 and 3 are set to the current signal of 4 to 20 mA DC. The type of output signal can be determined separately for each of the analog outputs listed above, using the following three parameters.
Analog output-1: Analog output-1 type (AO1)
Analog output-2: Analog output-2 type (AO2)
Analog output-3: Analog output-3 type (AO3)

• Parallel-mode Output

The following explains an example of letting "Analog OUTPUT-1 (terminals ⑧ and ⑨)" and "Analog OUTPUT-3 (terminals ⑫ and ⑬)" present the parallel-mode characteristics of split computations.
[1]Set the Control Output Type (OT1) parameter to "2".
This sets the control output to "current output."
[2]Set the Retransmission Output1 (RET1) parameter to "3".
This sets the retransmission output to "control output retransmission."
[3]Set the Analog Output-1 100% Segmental Point (A1H) parameter to "100%".
[4]Set the Analog Output-1 0% Segmental Point (A1L) parameter to "25%".
[5]Set the Analog Output-3 100% Segmental Point (A3H) parameter to "75%".
[6]Set the Analog Output-3 0% Segmental Point (A3L) parameter to "0%".

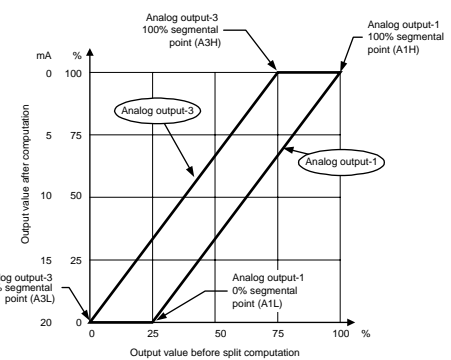

The figure on the right shows an example where both analog outputs-1 and 3 are set to the current signal of 20 to 0 mA DC. The type of output signal can be determined separately for each of the analog outputs listed above, using the following three parameters.
Analog output-1: Analog output-1 type (AO1)
Analog output-2: Analog output-2 type (AO2)
Analog output-3: Analog output-3 type (AO3)

● Communication Parameters

Located in: Main menu = UTMD ; Submenu = R485

Parameter Symbol	Name of Parameter	Setting Range and Description	Initial Value	User Setting	Target Item in CD-ROM
PSL1	Protocol selection-1	0: PC link communication 1: PC link communication (with sum check) 2: Ladder communication 3: Coordinated master station 4: Coordinated slave station 7: MODBUS (ASCII) 8: MODBUS (RTU) 9: Coordinated master station (2 loop mode) 10: Coordinated slave station (loop-1 mode) 11: Coordinated slave station (loop-2 mode) Terminal numbers: ⑧, ⑨, ⑫ and ⑬ (terminals for 4-wire connection)	0		Communication
BPS1	Baud rate-1	600, 1200, 2400, 4800, 9600 (bps)	9600		
PRI1	Parity-1	NONE: None EVEN: Even ODD: Odd	EVEN		
STP1	Stop bit-1	1, 2	1		

Parameter Symbol	Name of Parameter	Setting Range and Description	Initial Value	User Setting	Target Item in CD-ROM
DLN1	Data length -1	7, 8: 7 is fixed for MODBUS (ASCII) 8 is fixed for MODBUS (RTU), Ladder	8		
ADR1	Address-1	1 to 99 However, the maximum number of stations connectable is 31.	1		
RP.T1	Minimum response time-1	0 to 10 (× 10 ms)	0		
PSL2	Protocol selection -2	0: PC link communication 1: PC link communication (with sum check) 2: Ladder communication 3: Coordinated master station 4: Coordinated slave station 5: I/O expansion (for single-controller applications) 6: I/O expansion (for dual-controller applications) 9: Coordinated master station (2 loop mode) 10: Coordinated slave station (loop-1 mode) 11: Coordinated slave station (loop-2 mode) Terminal numbers: ⑧, ⑨ and ⑫ (terminals for 2-wire connection)	0		Communication Functions
BPS2	Baud rate-2	600, 1200, 2400, 4800, 9600, 19200, 38400 (bps)	9600		
PRI2	Parity-2	NONE: None EVEN: Even ODD: Odd	EVEN		
STP2	Stop bit-2	1, 2	1		
DLN2	Data length -2	7 or 8 8 is fixed for Ladder	8		
ADR2	Address-2	1 to 99 However, the maximum number of stations connectable is 31.	1		
RP.T2	Minimum response time-2	0 to 10 (× 10 ms)	0		

● Motor-driven Calibration-related Parameters (Displayed for Position Proportional Controllers)

Located in: Main menu = UTMD ; Submenu = VALV

Parameter Symbol	Name of Parameter	Setting Range and Description	Initial Value	User Setting	Target Item in CD-ROM
V.AT	Valve auto tuning	Automatically adjusts the fully-closed and fully-opened positions of a valve. When this function is used, there is no need for adjustment using the parameters V.RS, V.L and V.H. OFF: ON: Start automatic adjustment	OFF		
V.RS	Valve position setting reset	The parameters V.RS, V.L and V.H are designed for manual adjustment of valve positions. Setting V.RS to 1 resets the valve adjustment settings and causes the indication "V.RS" to blink.	0		
V.L	Fully-closed valve position setting	Pressing the SET/ENT key with valve position set to the fully-closed position causes the adjusted value to be stored.	Undefined		
V.H	Fully-opened valve position setting	Pressing the SET/ENT key with valve position set to the fully-opened position causes the adjusted value to be stored. When V.H adjustment is complete, V.H stops blinking.	Undefined		
TR.T	Valve traveling time	Used to operate a valve according to the estimated valve position. Set the time required for the valve to open fully from a state of being fully closed. Confirm the valve traveling time by consulting the datasheet of the valve's specifications. The valve traveling time is only effective when Valve Adjustment Mode (V.MOD) is set to 1 or 2.	60 seconds		
V.MOD	Valve adjusting mode	0: Valve position feedback type 1: Valve position feedback type (moves to the estimating type if a valve input error or wire burnout occurs.) 2: Valve position estimating type	0		

● Parameter-initializing Parameters

Located in: Main menu = UTMD ; Submenu = INIT